

DRAWING STATUS		PPAP	
REVISION	28	SIG	D BAILEY
		21-Nov-23	
PRD NUMBER PRD232129 WAS PRD139511			

PART NUMBER EXAMPLE :-
 0R3/0165006R VALVE DENOTES
 65mm RELIEF VALVE SET AT 165 PSIG
 PRESSURE SEAL MATERIAL VITON A

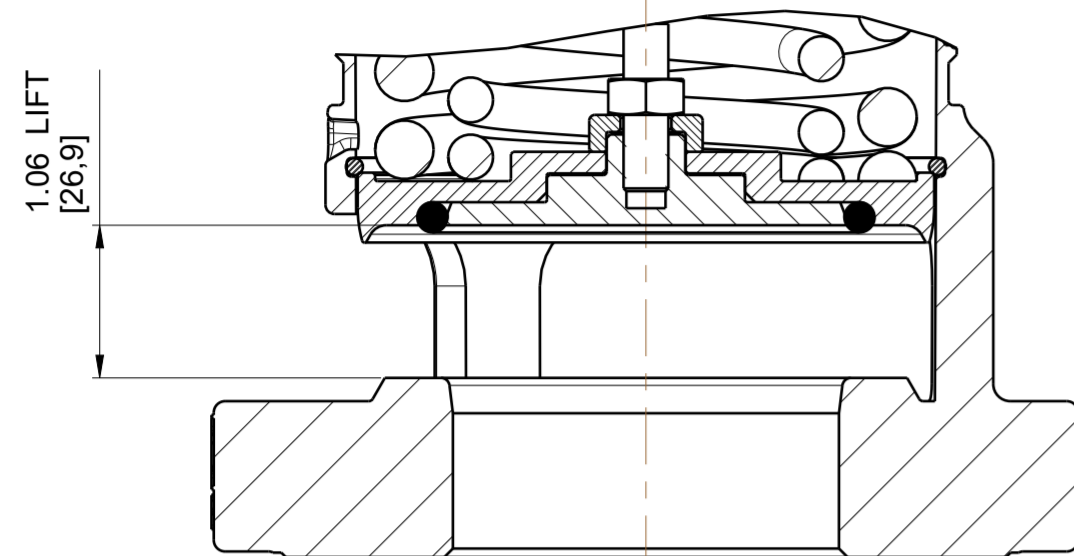

SECTION A-A
 SCALE 3:4
 VALVE IN OPEN POSITION

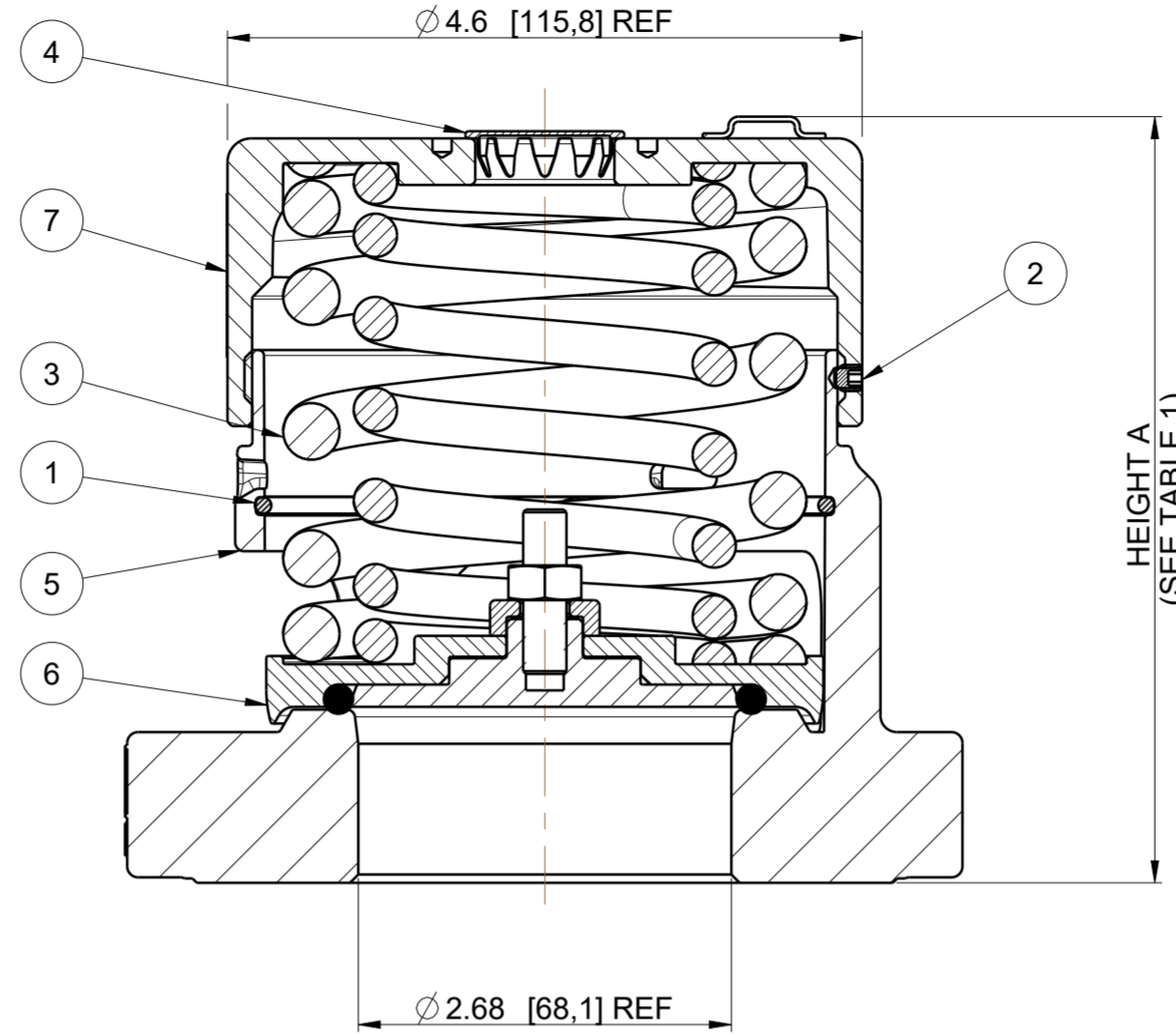

SECTION A-A

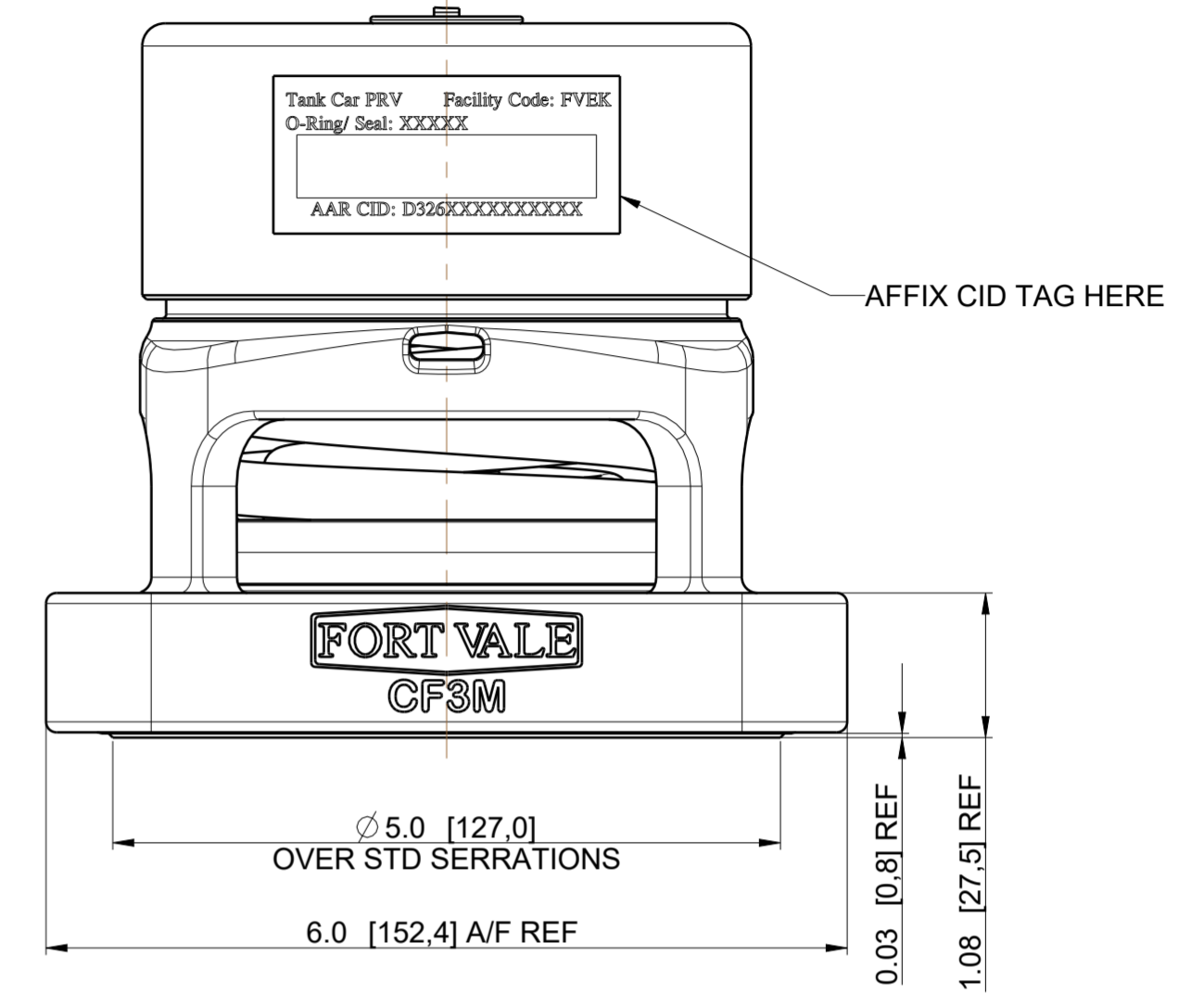

AAR APPLICATION NUMBER: PRD232129

MATERIAL MUST CONFORM TO:
 ASME SA351 CF3M, ASTM CF3M (YEAR DATE)
 ASME SA479 316L, ASTM A479 316L (YEAR DATE)

DESIGN CODES: AAR M1002, ASME VIII DIV1
 DESIGN PRESSURE (MAWP) : 165 PSI (11,38 BAR)
 SERVICE TEST PRESSURE : 283 PSI (19,50 BAR)
 MAX DESIGN TEMPERATURE : 302 °F (150 °C)
 MIN DESIGN TEMPERATURE : -67 °F (-55 °C) } FOR METAL PARTS
 REFER TO TABLE 2 FOR SEAL TEMPERATURE LIMITATIONS

4 HOLES Ø 0.87 [22,0] THRO'
 EQUI-SPACED AS SHOWN
 ON A 6.25 [158,8] PCD

NOTE!
 REPLACE MONTH/YEAR
 WITH CURRENT DATE
 INFORMATION
 E.G. MAY/2024.

CAP TO BE LASER MARKED
 AS SHOWN WITH X'S TO BE
 FILLED IN WITH CORRECT
 INFORMATION UPON
 COMPLETION OF ASSEMBLY

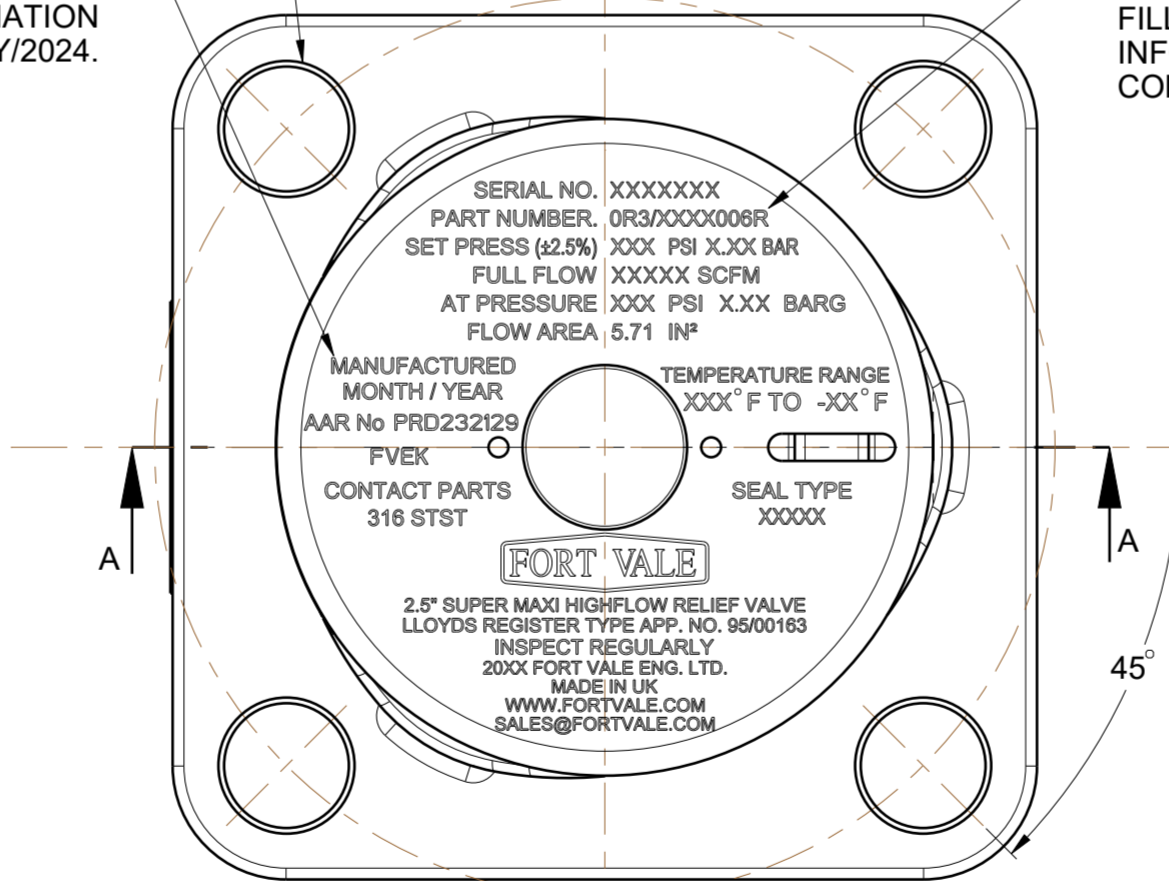

0R3/XXXX006R	SEAL MATERIAL	1860/U190XX	-15° C (+5° F)	150° C (302° F)
0R3/WXXX006R	WHITE BUNA N (FOOD GRADE)	1860/W190XX	-30° C (-22° F)	100° C (212° F)
0R3/SXXX006R	VITON GF-S (PEROXIDE CURED)	1860/S190XX	-20° C (-4° F)	150° C (302° F)
0R3/TXXX006R	FORTYT PFA OUTER/SILICON CORE	1860/T190XX	-55° C (-67° F)	150° C (302° F)
0R3/NXXX006R	WHITE NEOPRENE (FOOD GRADE)	1860/Y190XX	-30° C (-22° F)	100° C (212° F)
0R3/KXXX006R	KALREZ 7275	1860/L190XX	-20° C (-4° F)	150° C (302° F)
0R3/JXXX006R	FORTYT FEP OUTER/VITON	1860/J190XX	-20° C (-4° F)	150° C (302° F)
0R3/HXXX006R	BLACK EPDM (PEROXIDE CURED)	1860/M190XX	-46° C (-50° F)	121° C (250° F)
0R3/GXXX006R	VITON GFLT	1860/G190XX	-25° C (-13° F)	150° C (302° F)
0R3/FXXX006R	BLACK NEOPRENE	1860/Q190XX	-45° C (-49° F)	100° C (212° F)
0R3/EXXX006R	VITON GF-S (TRELLEBORG MATL. CS5350)	1860/P190XX	-20° C (-4° F)	150° C (302° F)
0R3/DXXX006R	WHITE EPDM FDA APPROVED	1860/D190XX	-50° C (-58° F)	150° C (302° F)
0R3/CXXX006R	CHEMRAZ 505	1860/C190XX	-30° C (-22° F)	150° C (302° F)
0R3/BXXX006R	VITON B (DUPONT)	1860/B190XX	-20° C (-4° F)	150° C (302° F)
0R3/AXXX006R	AFLAS	1860/A190XX	-30° C (-22° F)	150° C (302° F)
0R3/9XXX006R	EPDM	1860/E190XX	-50° C (-58° F)	150° C (302° F)
0R3/7XXX006R	PERFLUOROELASTOMER	1860/K190XX	-15° C (+5° F)	150° C (302° F)
0R3/4XXX006R	BLACK BUNA N (NITRILE)	1860/N190XX	-30° C (-22° F)	100° C (212° F)
0R3/3XXX006R	KALREZ 6375	1860/R190XX	-15° C (+5° F)	150° C (302° F)
0R3/1XXX006R	FORTYT FEP OUTER/SILICON CORE	1860/F190XX	-55° C (-67° F)	150° C (302° F)
0R3/0XXX006R	VITON A	1860/V190XX	-20° C (-4° F)	150° C (302° F)

TABLE 2

0R3/X165006R	1860/0041/5	1860/X19054	6104-1264R	SPRING PAIR	165,0 [11,38]		22286 [10,52]	198,0 [13,66]	24000 [11,33]	214,5 [14,79]	17,0 (7,7)	5,50 (139,8)	
0R3/X075006R	1760/0028	1860/X19060	6104-0570	SPRING PAIR	75,0 [5,17]	9564,7 [4,51]	85,0 [5,86]	10131 [4,78]	90,0 [6,21]	11052 [5,22]	97,5 [6,72]	14,0 (6,3)	4,42 (112,4)
PART NUMBER	TOP CAP (ITEM 6)	PRESSURE PLATE (ITEM 8)	INNER PRESSURE SPRINGS	OUTER PRESSURE SPRINGS	SET PRESSURE PSI [BAR]	113% CERTIFIED FULL FLOW SCFM [SM ³ /S]	113% OVER PRESSURE PSI [BAR]	120% CERTIFIED FULL FLOW SCFM [SM ³ /S]	120% OVER PRESSURE PSI [BAR]	130% CERTIFIED FULL FLOW SCFM [SM ³ /S]	130% OVER PRESSURE PSI [BAR]	MASS lb [kg]	HEIGHT A inch [mm]

TABLE 1

7	XXXX/XXXX	TOP CAP (SEE TABLE 1)	304 STST	1
6	1860/X190XX	COMPOSITE PRESSURE PLATE (SEE TABLES 1&2)	316 STST	1
5	1860/0625	VALVE BODY MACHINED	CF3M	1
4	10978/1	STAINLESS PLUG	304L STST	1
3	6104-XXXX	PRESSURE SPRING (SEE TABLE 1)	17/7 SS	1
2	5121-001	3/16"BSW.3/16"LG SOCKETHEAD	A2-70	1
1	5120-067	RETAINING RING CLIP	316 STST	1
Index	Part Number	Description	Material	Qty

Assembly BOM

SALES@FORTVALE.COM WWW.FORTVALE.COM

ENGLAND, USA, CHINA
NETHERLANDS, SINGAPORE

© FORT VALE ENGINEERING LTD 2023.

DO NOT SCALE - IF IN DOUBT ASK

UNLESS OTHERWISE STATED

FIRST ANGLE PROJECTION

MATERIAL: 316L STST

SCALE: NTS MASS: SEE TABLE 1

CHECKED DVN: 38739

DESCRIPTION: 2 1/2" SUPERMAXI HIGHFLOW R/V

TYPE: MK3 SUPER MAXI HIGH FLOW

SHEET 1 OF 1

DRAWN BY: P BOULT DATE: 28-Aug-13

DRG.NO. 0R3/XXXX006R

DRAWING STATUS		Production	
REVISION	14	SIG	D BAILEY
			22-Nov-23
PRD NUMBER PRD232129 WAS PRD139511			

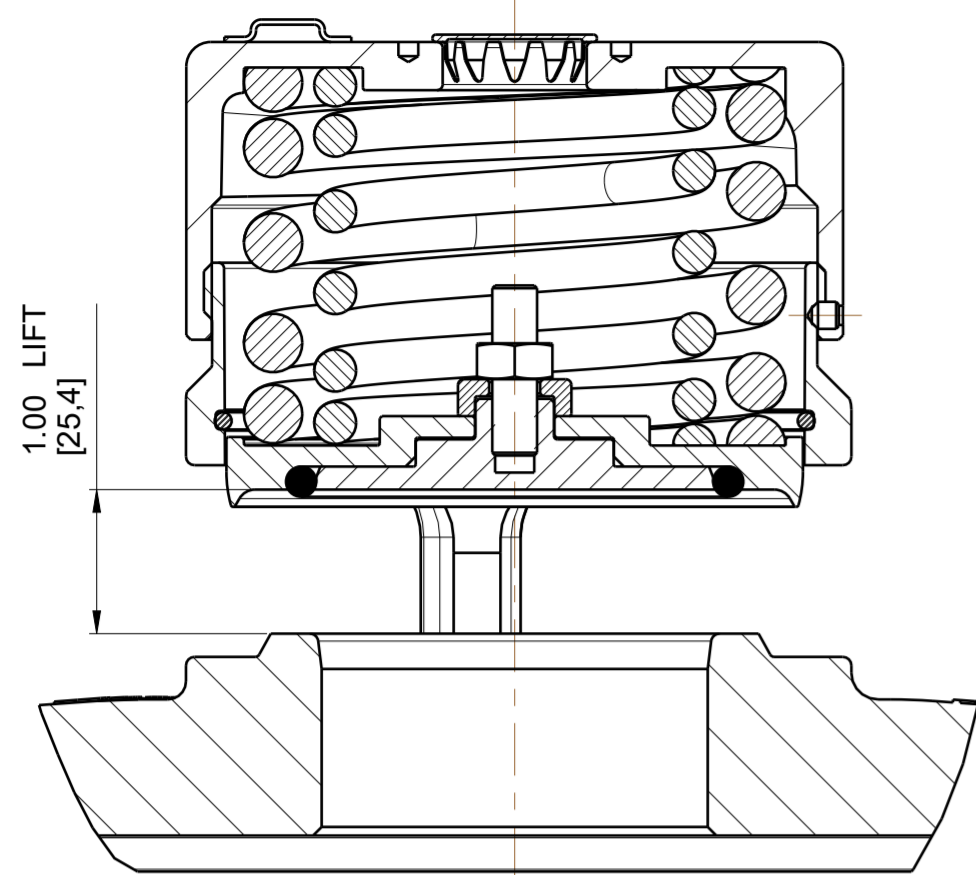

VALVE IN OPEN POSITION
SECTION A-A
SCALE 3:4

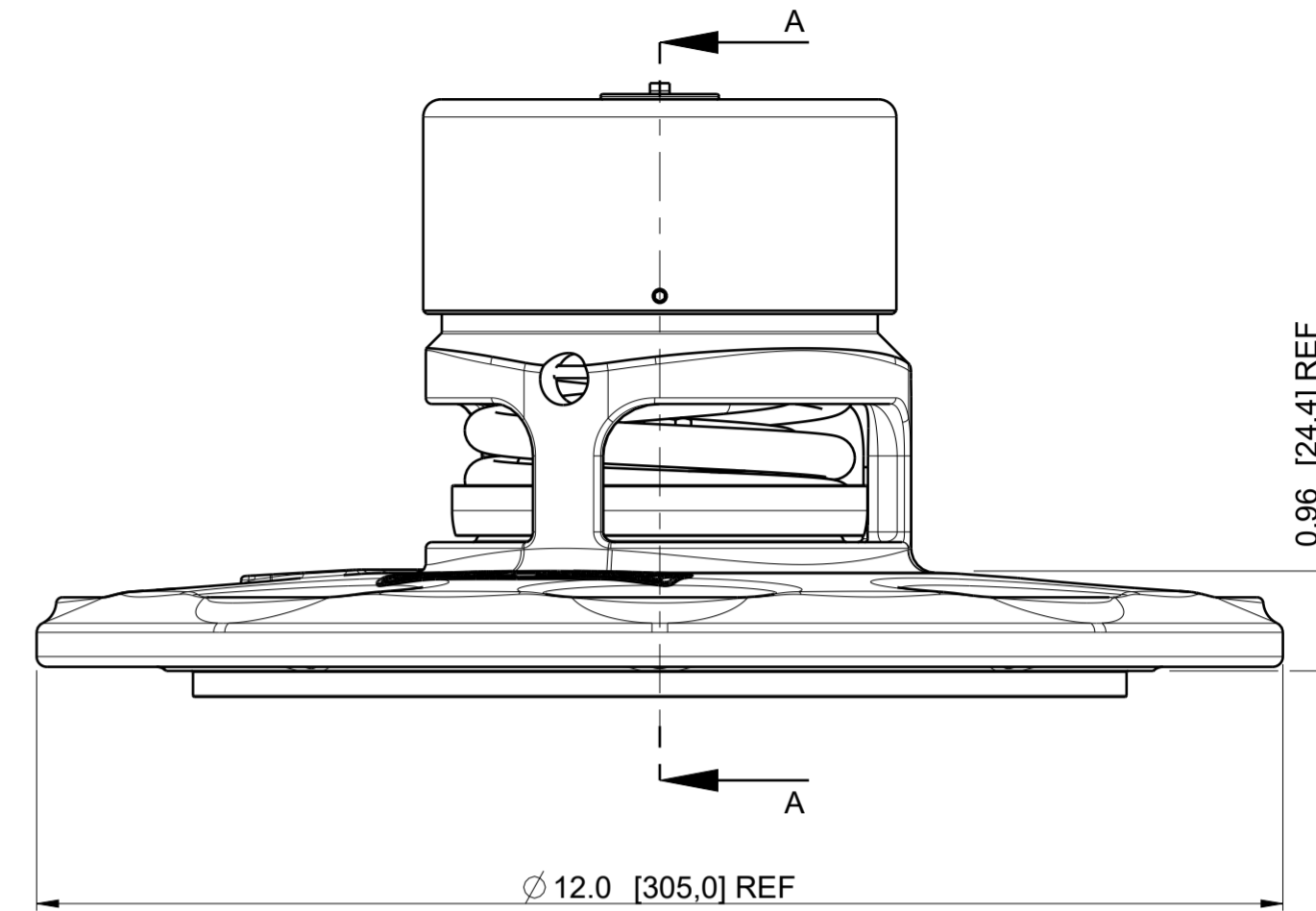
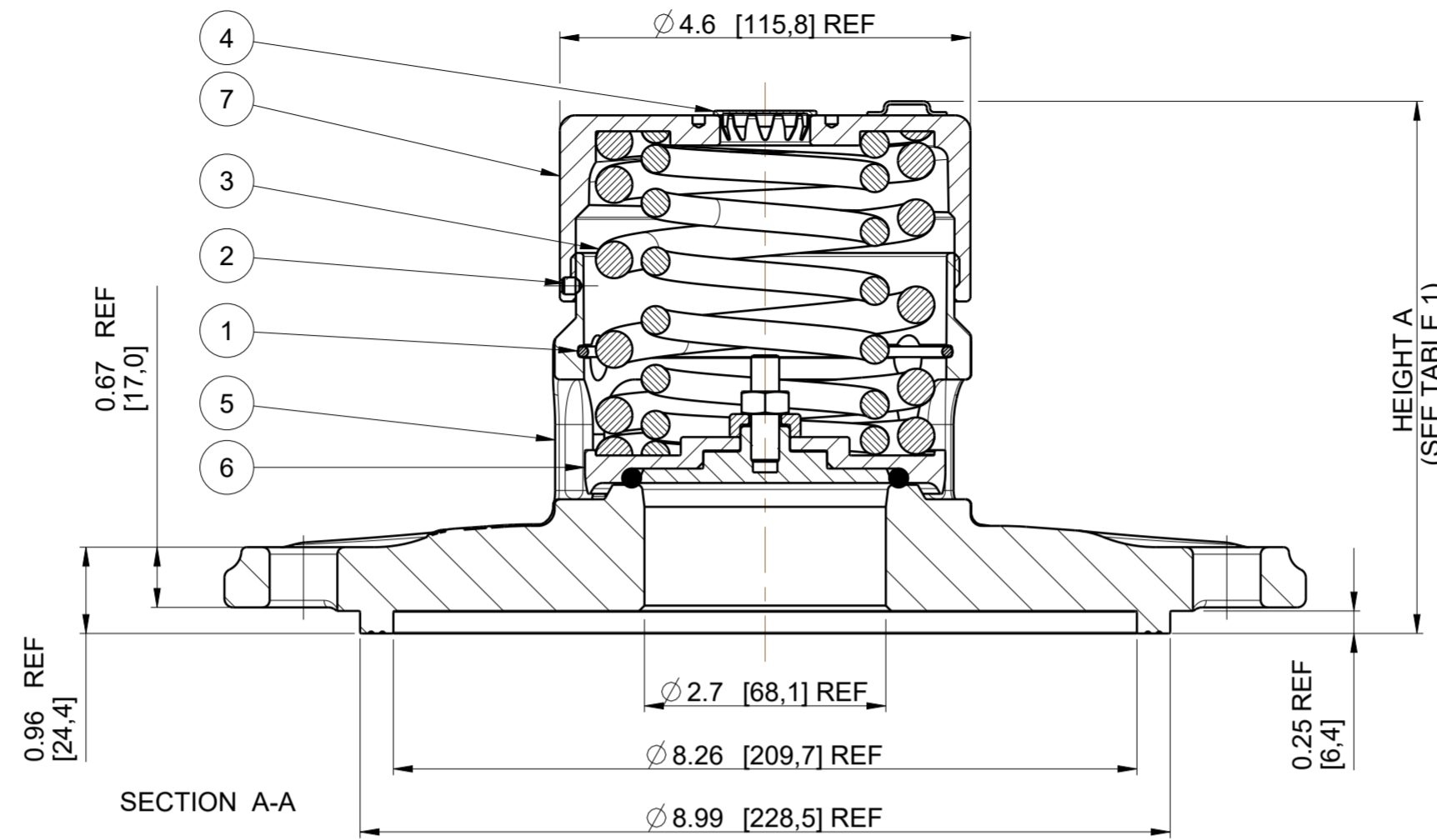

PART NUMBER EXAMPLE :-
0R3/0075006S VALVE DENOTES
65mm RELIEF VALVE SET AT 75 PSIG
PRESSURE SEAL MATERIAL VITON A

AAR APPLICATION NUMBER: PRD232129

MATERIAL MUST CONFORM TO:
ASME SA351 CF8M, ASTM CF8M (YEAR DATE)
ASME SA479 316L, ASTM A479 316L(YEAR DATE)

8 HOLES $\phi 0.75$ [19,10]
EQUISPACED AS SHOWN
ON A 10.25 [260,4] PCD

NOTE!
REPLACE MONTH/YEAR
WITH CURRENT DATE
INFORMATION
E.G. MAY/2016

AFFIX CID TAG HERE

CAP TO BE LASER MARKED AS SHOWN
WITH X'S TO BE FILLED IN WITH
CORRECT INFORMATION
UPON COMPLETION OF ASSEMBLY

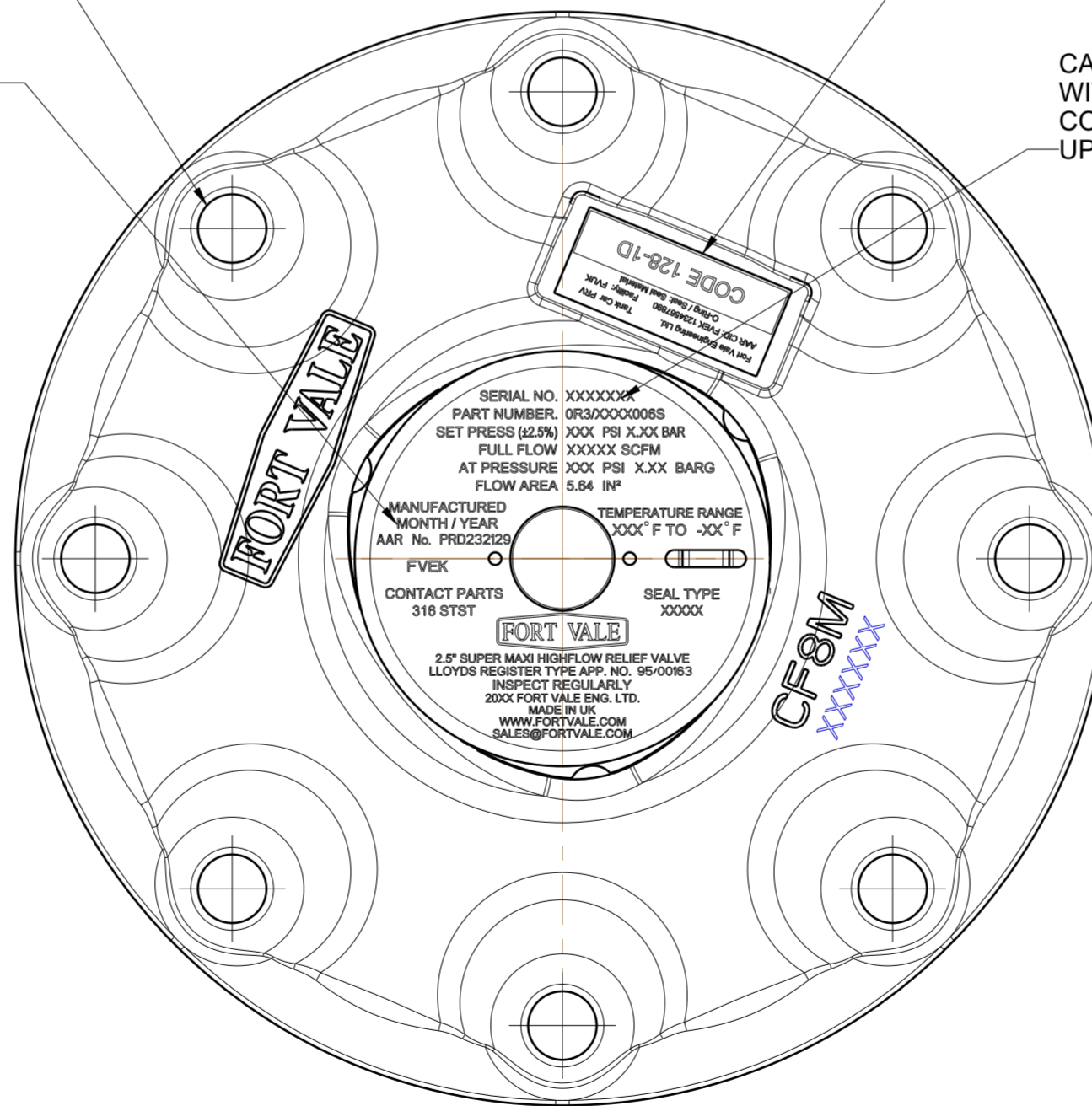

DESIGN CODES: AAR M1002, ASME VIII DIV1
DESIGN PRESSURE (MAWP) : 165 PSI (11,38 BAR)
SERVICE TEST PRESSURE : 283 PSI (19,50 BAR)
MAX DESIGN TEMPERATURE : 302 °F (150 °C)
MIN DESIGN TEMPERATURE : -67 °F (-55 °C) } FOR METAL PARTS
REFER TO TABLE 2 FOR SEAL TEMPERATURE LIMITATIONS

OR3/UXXX006S	VITON B (TRELLEBORG 4273B)	1860/U190XX	-15° C (+5° F)	150° C (302° F)
0R3/WXXX006S	WHITE BUNA N (FOOD GRADE)	1860/W190XX	-30° C (-22° F)	100° C (212° F)
0R3/SXXX006S	VITON GF-S (PEROXIDE CURED)	1860/S190XX	-20° C (-4° F)	150° C (302° F)
0R3/TXXX006S	FORTYT PFA OUTER/SILICON CORE	1860/T190XX	-55° C (-67° F)	150° C (302° F)
0R3/NXXX006S	WHITE NEOPRENE (FOOD GRADE)	1860/Y190XX	-30° C (-22° F)	100° C (212° F)
0R3/HXXX006S	BLACK EPDM (PEROXIDE CURED)	1860/M190XX	-46° C (-50° F)	121° C (250° F)
0R3/GXXX006S	VITON GFLT	1860/G190XX	-25° C (-13° F)	150° C (302° F)
0R3/FXXX006S	BLACK NEOPRENE	1860/Q190XX	-45° C (-49° F)	100° C (212° F)
0R3/EXXX006S	VITON GF-S (TRELLEBORG CS5350)	1860/P190XX	-20° C (-4° F)	150° C (302° F)
0R3/DXXX006S	WHITE EPDM (FOOD GRADE)	1860/D190XX	-50° C (-58° F)	150° C (302° F)
0R3/CXXX006S	CHEMRAZ 505	1860/C190XX	-30° C (-22° F)	150° C (302° F)
0R3/BXXX006S	VITON B (DUPONT)	1860/B190XX	-15° C (+5° F)	150° C (302° F)
0R3/AXXX006S	AFLAS	1860/A190XX	-30° C (-22° F)	150° C (302° F)
0R3/9XXX006S	EPDM	1860/E190XX	-50° C (-58° F)	150° C (302° F)
0R3/7XXX006S	PERFLUOROELASTOMER	1860/K190XX	-15° C (+5° F)	150° C (302° F)
0R3/4XXX006S	BLACK BUNA N (NITRILE)	1860/N190XX	-30° C (-22° F)	100° C (212° F)
0R3/3XXX006S	KALREZ 6375	1860/R190XX	-15° C (+5° F)	150° C (302° F)
0R3/1XXX006S	FORTYT FEP OUTER/SILICON CORE	1860/F190XX	-55° C (-67° F)	150° C (302° F)
0R3/0XXX006S	VITON A	1860/V190XX	-20° C (-4° F)	150° C (302° F)
PART NUMBER	SEAL MATERIAL	PRESSURE PLATE	MIN TEMP	MAX TEMP

TABLE 2

PART NUMBER	TOP CAP (ITEM 5)	PRESSURE PLATE (ITEM 7)	INNER PRESSURE SPRINGS	OUTER PRESSURE SPRINGS	SET PRESSURE PSI [BAR]	113% CERTIFIED FULL FLOW SCFM [SM ³ /S]	113% OVER PRESSURE PSI [BAR]	120% CERTIFIED FULL FLOW SCFM [SM ³ /S]	120% OVER PRESSURE PSI [BAR]	130% CERTIFIED FULL FLOW SCFM [SM ³ /S]	130% OVER PRESSURE PSI [BAR]	MASS lb [kg]	HEIGHT A inch [mm]
0R3/X165006S	1860/0041/5	1860/X19054	6104-1264R	SPRING PAIR	165,0 [11,38]			22286 [10,52]	198,0 [13,66]	24000 [11,33]	214,5 [14,79]	33,6 [15,2]	5,91 [150,1]
0R3/X075006S	1760/0028	1860/X19060	6104-0570	SPRING PAIR	75,0 [5,17]	9564.7 [4,51]	85,0 [5,86]	10131 [4,78]	90,0 [6,21]	11052 [5,22]	97,5 [6,72]	30,6 [13,9]	4,83 [122,7]

TABLE 1

7	XXXX/XXXX	TOP CAP (SEE TABLE 1)	304 STST	1
6	1860/X190XXX	COMPOSITE PRESSURE PLATE (SEE TABLES 1&2)	316 STST	1
5	1860/0627	RAIL MAXI BODY MACHINING	CF3M	1
4	10978/1	STAINLESS PLUG	304L STST	1
3	6104-XXXX	PRESSURE SPRING (SEE TABLE 1)	17/7 SS	1
2	5121-001	3/16"BSW.3/16"LG SOCKETHEAD	A2-70	1
1	5120-067	RETAINING RING CLIP	316 STST	1
Index	Part Number	Description	Material	Qty

Assembly BOM

FORT VALE SALES@FORTVALE.COM WWW.FORTVALE.COM
ENGLAND, USA, CHINA
NETHERLANDS, SINGAPORE

© FORT VALE ENGINEERING LTD 2023.

DO NOT SCALE- IF IN DOUBT ASK

UNLESS OTHERWISE STATED
FIRST ANGLE PROJECTION
X.X ±0.5
X.XX ±0.25
X.XXX ±0.125
ANGLES ±0.5°
SURFACE FINISH 3.2um MAX
CORNER RADII 0.8
CORNER CHAMFER 1.0 X 45°
REMOVE ALL BURRS AND SHARP EDGES

MATERIAL: CF8M

SCALE: 9:16 MASS: SEE TABLE 1

CHECKED DVN: 38739

DESCRIPTION SHEET 1 OF 1

2.5" SUPERMAXI HIGHFLOW R/V

DRAWN BY: D BAILEY DATE: 07-Jun-16

TYPE MK3 SUPER MAXI HIGH FLOW

DRG.NO. 0R3/XXXX006S

A2 UNITS mm

PART NUMBER EXAMPLE :-
 0R3/0165006T/A VALVE DENOTES
 65mm RELIEF VALVE SET AT 165 PSIG
 PRESSURE SEAL MATERIAL VITON A

PARTS NOTED IN TABLE CORROSION TESTED
 AS PER NOTE
 YES = ALL COMPONENTS TEST
 NO = NOT TESTED
 WETTED= ONLY WETTED PARTS TESTED

IDENTIFIED COMPONENTS MATERIALS ARE TESTED IN
 ACCORDANCE WITH ASTM A262, PRACTICE "A". IF PRACTICE
 "A" REQUIREMENTS CANNOT BE MET, TESTING
 MATERIAL IN ACCORDANCE WITH ASTM
 PRACTICE "B" OR PRACTICE "E" IS PERMISSIBLE.
 CORROSION RATE NOT TO
 EXCEED .004 INCHES PER MONTH (ipm).

DRAWING STATUS		PPAP	
REVISION	07	SIG	D BAILEY
			22-Nov-23

PRD NUMBER PRD232129 WAS PRD139511

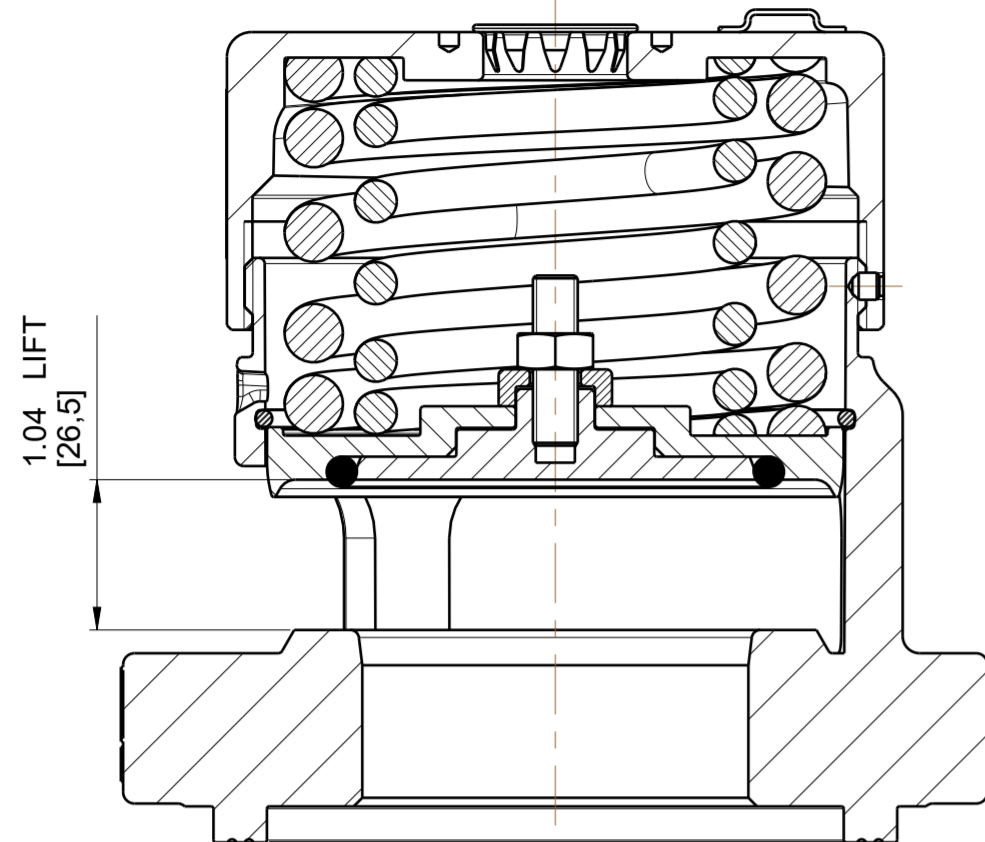

VALVE IN OPEN POSITION
 SECTION A-A
 SCALE 3:4

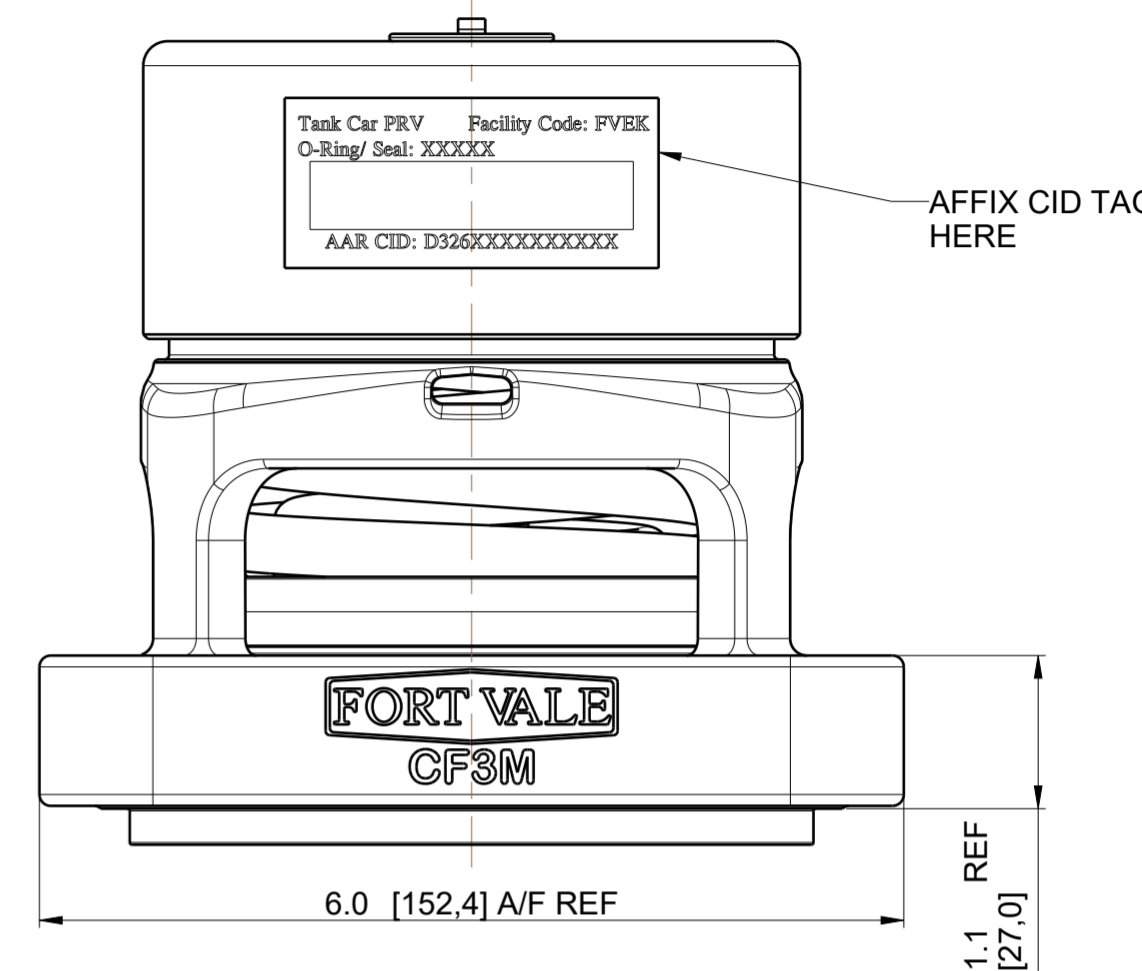
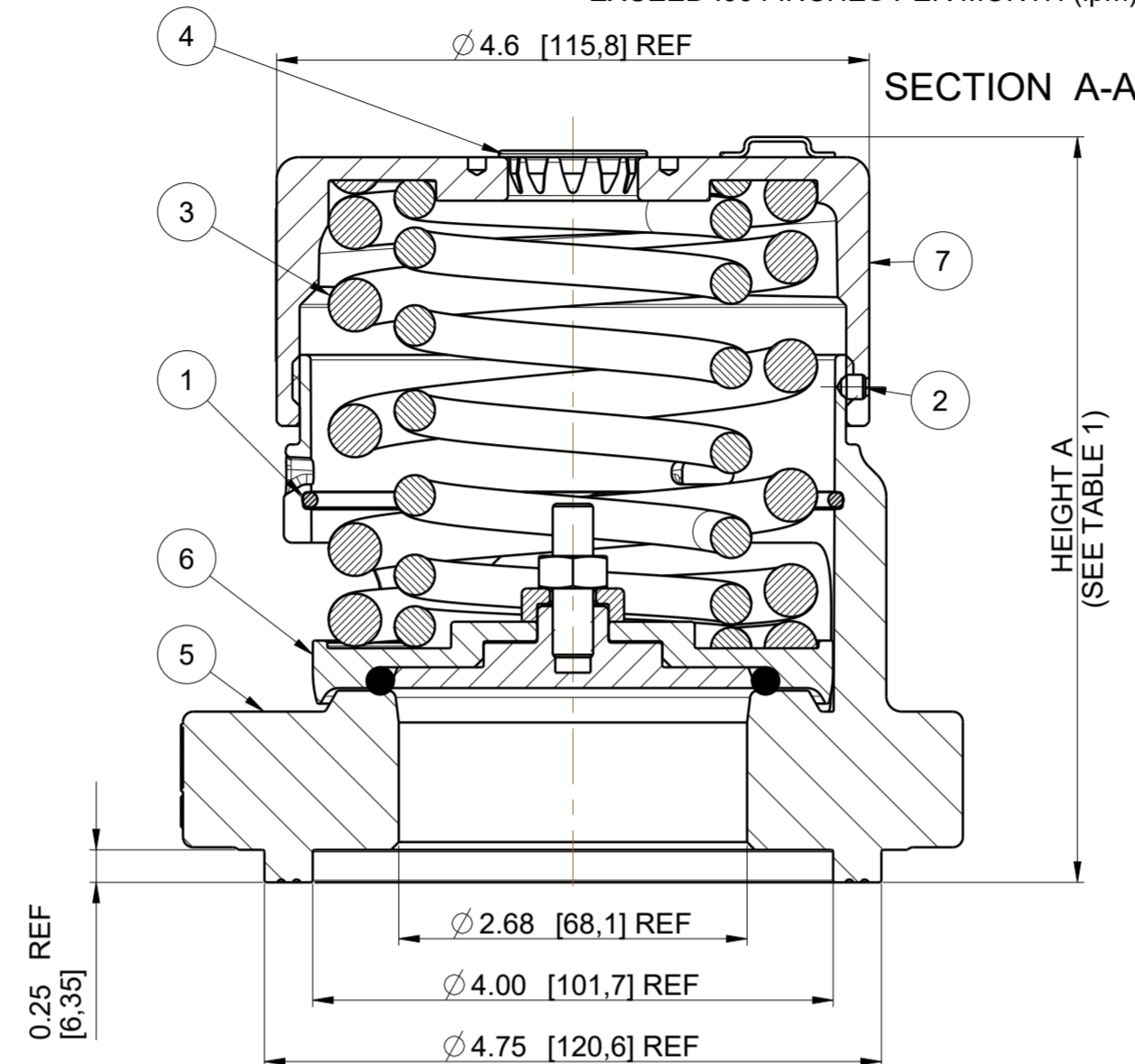

AAR APPLICATION NUMBER: PRD232129

DESIGN CODES: AAR M1002, ASME VIII DIV1
 DESIGN PRESSURE (MAWP) : 165 PSI (11,38 BAR)
 SERVICE TEST PRESSURE : 283 PSI (19,50 BAR)
 MAX DESIGN TEMPERATURE : 302 °F (150 °C)
 MIN DESIGN TEMPERATURE : -67 °F (-55 °C) } FOR METAL PARTS

REFER TO TABLE 2 FOR SEAL TEMPERATURE LIMITATIONS

0R3/UXXX006T/A	VITON B (TRELLEBORG 4273B)	186A/U190XX	-15°C (+5°F)	150°C (302°F)
0R3/WXXX006T/A	WHITE BUNA N (FOOD GRADE)	186A/W190XX	-30°C (-22°F)	100°C (212°F)
0R3/SXXX006T/A	VITON GF-S (PEROXIDE CURED)	186A/S190XX	-20°C (-4°F)	150°C (302°F)
0R3/TXXX006T/A	FORTYT PFA OUTER/SILICON CORE	186A/T190XX	-55°C (-67°F)	150°C (302°F)
0R3/NXXX006T/A	WHITE NEOPRENE (FOOD GRADE)	186A/Y190XX	-30°C (-22°F)	100°C (212°F)
0R3/KXXX006T/A	KALREZ 7275	186A/L190XX	-20°C (-4°F)	150°C (302°F)
0R3/HXXX006T/A	BLACK EPDM (PEROXIDE CURED)	186A/M190XX	-46°C (-50°F)	121°C (250°F)
0R3/GXXX006T/A	VITON GFLT	186A/G190XX	-25°C (-13°F)	150°C (302°F)
0R3/FXXX006T/A	BLACK NEOPRENE	186A/Q190XX	-45°C (-49°F)	100°C (212°F)
0R3/EXXX006T/A	VITON GF-S (TRELLEBORG CS5350)	186A/P190XX	-20°C (-4°F)	150°C (302°F)
0R3/DXXX006T/A	WHITE EPDM (FOOD GRADE)	186A/D190XX	-50°C (-58°F)	150°C (302°F)
0R3/CXXX006T/A	CHEMRAZ 505	186A/C190XX	-30°C (-22°F)	150°C (302°F)
0R3/BXXX006T/A	VITON B (DUPONT)	186A/B190XX	-15°C (+5°F)	150°C (302°F)
0R3/AXXX006T/A	AFLAS	186A/A190XX	-30°C (-22°F)	150°C (302°F)
0R3/9XXX006T/A	EPDM	186A/E190XX	-50°C (-58°F)	150°C (302°F)
0R3/7XXX006T/A	PERFLUOROELASTOMER	186A/K190XX	-15°C (+5°F)	150°C (302°F)
0R3/4XXX006T/A	BLACK BUNA N (NITRILE)	186A/N190XX	-30°C (-22°F)	100°C (212°F)
0R3/3XXX006T/A	KALREZ 6375	186A/R190XX	-15°C (+5°F)	150°C (302°F)
0R3/1XXX006T/A	FORTYT FEP OUTER/SILICON CORE	186A/F190XX	-55°C (-67°F)	150°C (302°F)
0R3/0XXX006T/A	VITON A	186A/V190XX	-20°C (-4°F)	150°C (302°F)

TABLE 2

4 HOLES Ø0.87 [22,0] THRO'
 EQUI-SPACED AS SHOWN
 ON A 6.25 [158,8] PCD

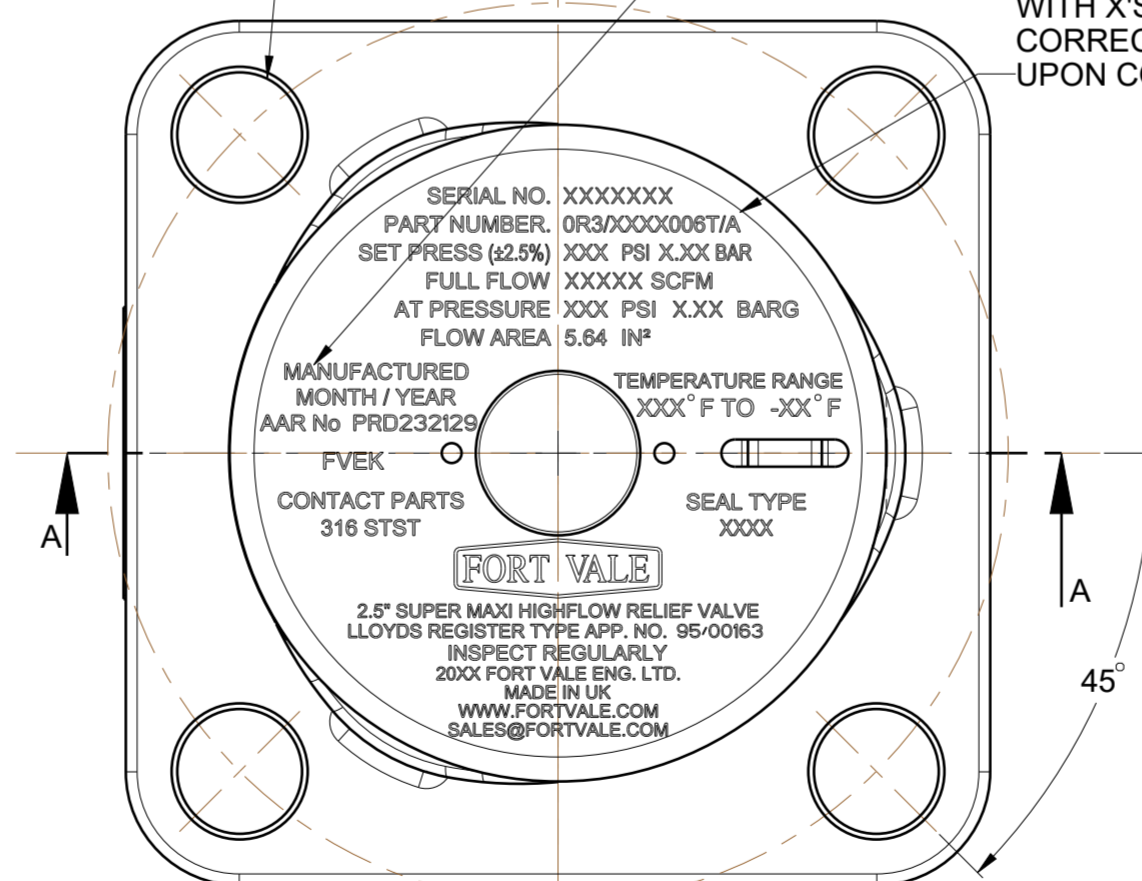

NOTE!
 REPLACE MONTH/YEAR
 WITH CURRENT DATE
 INFORMATION
 E.G. MAY/2016

CAP TO BE LASER MARKED AS SHOWN
 WITH X'S TO BE FILLED IN WITH
 CORRECT INFORMATION
 UPON COMPLETION OF ASSEMBLY

Index	Part Number	Description	Material	Qty	Test Note
7	XXXX/XXXX	TOP CAP (SEE TABLE 1)	304 STST	1	NO
6	186A/X190XX	COMPOSITE PRESSURE PLATE (SEE TABLES 1&2)	VARIOUS	1	WETTED
5	1860/0626	VALVE BODY MACHINED	CF3M	1	YES
4	10978/1	STAINLESS PLUG	304L STST	1	NO
3	6104-XXXX	PRESSURE SPRING (SEE TABLE 1)	17/7 SS	1	NO
2	5121-001	3/16"BSW.3/16"LG SOCKETHEAD	A2-70	1	NO
1	5120-067	RETAINING RING CLIP	316 STST	1	NO

Assembly BOM

SALES@FORTVALE.COM WWW.FORTVALE.COM

ENGLAND, USA, CHINA
NETHERLANDS, SINGAPORE

© FORT VALE ENGINEERING LTD 2023.

DO NOT SCALE - IF IN DOUBT ASK

UNLESS OTHERWISE STATED

FIRST ANGLE PROJECTION

MATERIAL: 316L STST

SCALE: NTS MASS: (SEE TABLE 1)

CHECKED DVN: 38739

DESCRIPTION: 2.5" SUPERMAXI HIGHFLOW R/V

TYPE: MK3 SUPER MAXI HIGH FLOW

SHEET 1 OF 1

DRAWN BY: D BAILEY DATE: 10-Feb-21

DRG.NO. OR3/XXXX006T/A

PART NUMBER	TOP CAP (ITEM 5)	PRESSURE PLATE (ITEM 6)	INNER PRESSURE SPRINGS	OUTER PRESSURE SPRINGS	SET PRESSURE PSI [BAR]	113% CERTIFIED FULL FLOW SCFM [SM ³ /S]	113% OVER PRESSURE PSI [BAR]	120% CERTIFIED FULL FLOW SCFM [SM ³ /S]	120% OVER PRESSURE PSI [BAR]	130% CERTIFIED FULL FLOW SCFM [SM ³ /S]	130% OVER PRESSURE PSI [BAR]	MASS lb [kg]	HEIGHT A inch [mm]
0R3/X165006T/A	1860/0041/5	186A/X19054	6104-1264R	SPRING PAIR	165,0 [11,38]			22286 [10,52]	198,0 [13,66]	24000 [11,33]	214,5 [14,79]	17,2 [7,8]	5,51 [139,9]
0R3/X075006T/A	1760/0028	186A/X19060	6104-0570	SPRING PAIR	75,0 [5,17]	9564.7 [4,51]	85,0 [5,86]	10131 [4,78]	90,0 [6,21]	11052 [5,22]	97,5 [6,72]	14,6 [6,6]	4,43 [112,5]

TABLE 1

PART NUMBER EXAMPLE :-
 0R3/0165006T VALVE DENOTES
 65mm RELIEF VALVE SET AT 165 PSIG
 PRESSURE SEAL MATERIAL VITON A

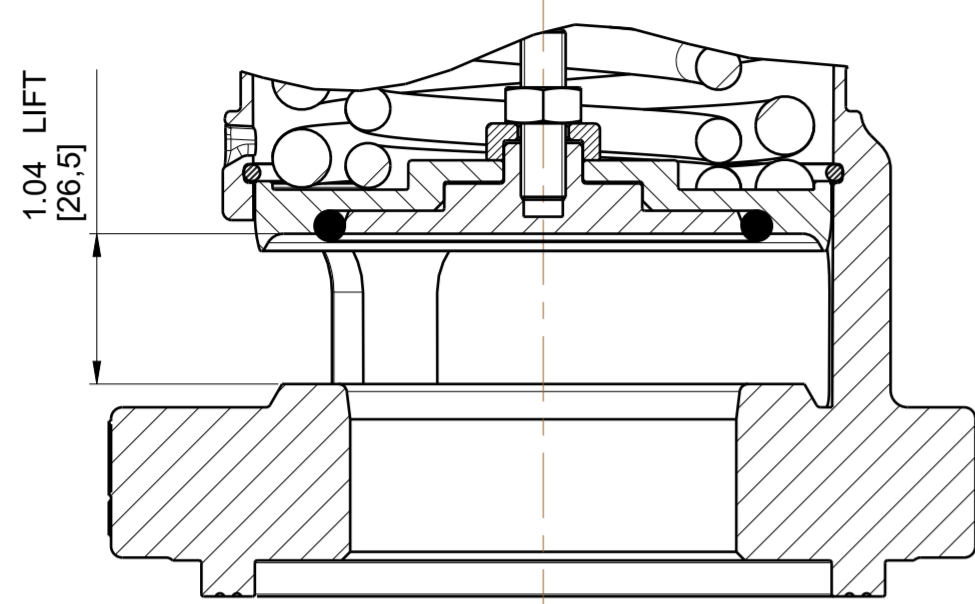

VALVE IN OPEN POSITION
 SECTION A-A
 SCALE 3:4

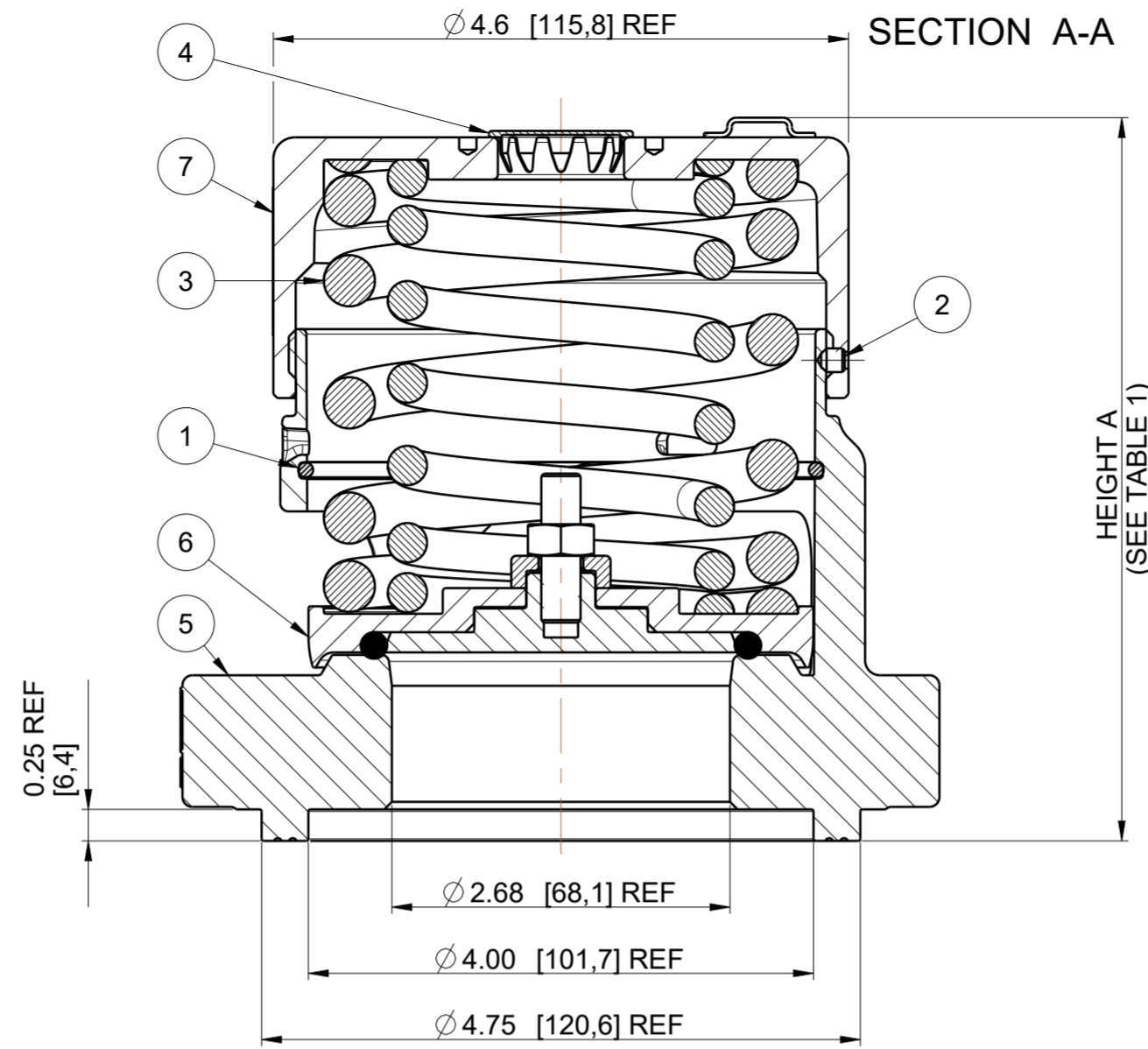

DRAWING STATUS		PPAP	
REVISION	25	SIG	D BAILEY
			22-Nov-23
PRD NUMBER PRD232129 WAS PRD139511			

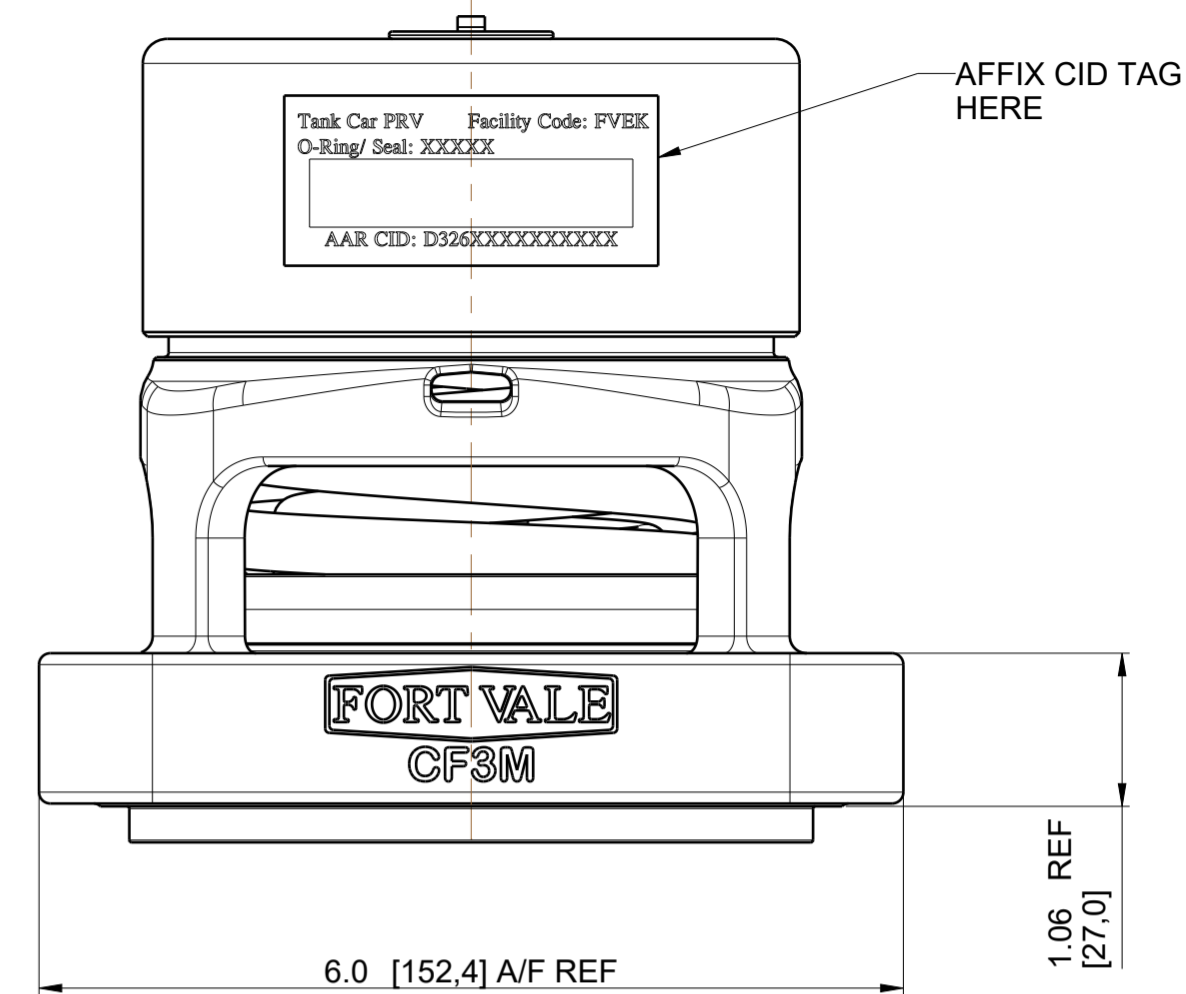

AAR APPLICATION NUMBER: PRD232129

MATERIAL MUST CONFORM TO:
 ASME SA351 CF3M, ASTM CF3M (YEAR DATE)
 ASME SA479 316L, ASTM A479 316L(YEAR DATE)

DESIGN CODES: AAR M1002, ASME VIII DIV1
 DESIGN PRESSURE (MAWP) : 165 PSI (11,38 BAR)
 SERVICE TEST PRESSURE : 283 PSI (19,50 BAR)
 MAX DESIGN TEMPERATURE : 302 °F (150 °C)
 MIN DESIGN TEMPERATURE : -67 °F (-55 °C) } FOR METAL PARTS
 REFER TO TABLE 2 FOR SEAL TEMPERATURE LIMITATIONS

0R3/UXXX006T	VITON B (TRELLEBORG 4273B)	1860/U190XX	-15° C (+5° F)	150° C (302° F)
0R3/WXXX006T	WHITE BUNA N (FOOD GRADE)	1860/W190XX	-30° C (-22° F)	100° C (212° F)
0R3/SXXX006T	VITON GF-S (PEROXIDE CURED)	1860/S190XX	-20° C (-4° F)	150° C (302° F)
0R3/TXXX006T	FORTYT PFA OUTER/SILICON CORE	1860/T190XX	-55° C (-67° F)	150° C (302° F)
0R3/NXXX006T	WHITE NEOPRENE (FOOD GRADE)	1860/Y190XX	-30° C (-22° F)	100° C (212° F)
0R3/KXXX006T	KALREZ 7275	1860/L190XX	-20° C (-4° F)	150° C (302° F)
0R3/HXXX006T	BLACK EPDM (PEROXIDE CURED)	1860/M190XX	-46° C (-50° F)	121° C (250° F)
0R3/GXXX006T	VITON GFLT	1860/G190XX	-25° C (-13° F)	150° C (302° F)
0R3/FXXX006T	BLACK NEOPRENE	1860/Q190XX	-45° C (-49° F)	100° C (212° F)
0R3/EXXX006T	VITON GF-S (TRELLEBORG CS5350)	1860/P190XX	-20° C (-4° F)	150° C (302° F)
0R3/DXXX006T	WHITE EPDM (FOOD GRADE)	1860/D190XX	-50° C (-58° F)	150° C (302° F)
0R3/CXXX006T	CHEMRAZ 505	1860/C190XX	-30° C (-22° F)	150° C (302° F)
0R3/BXXX006T	VITON B (DUPONT)	1860/B190XX	-15° C (+5° F)	150° C (302° F)
0R3/AXXX006T	AFLAS	1860/A190XX	-30° C (-22° F)	150° C (302° F)
0R3/9XXX006T	EPDM	1860/E190XX	-50° C (-58° F)	150° C (302° F)
0R3/7XXX006T	PERFLUOROELASTOMER	1860/K190XX	-15° C (+5° F)	150° C (302° F)
0R3/4XXX006T	BLACK BUNA N (NITRILE)	1860/N190XX	-30° C (-22° F)	100° C (212° F)
0R3/3XXX006T	KALREZ 6375	1860/R190XX	-15° C (+5° F)	150° C (302° F)
0R3/1XXX006T	FORTYT FEP OUTER/SILICON CORE	1860/F190XX	-55° C (-67° F)	150° C (302° F)
0R3/0XXX006T	VITON A	1860/V190XX	-20° C (-4° F)	150° C (302° F)

TABLE 2

NOTE!
 REPLACE MONTH/YEAR
 WITH CURRENT DATE
 INFORMATION
 E.G. MAY/2016

4 HOLES Ø0.87 [22,0] THRO'
 EQUI-SPACED AS SHOWN
 ON A 6.25 [158,8] PCD

CAP TO BE LASER MARKED AS SHOWN
 WITH X'S TO BE FILLED IN WITH
 CORRECT INFORMATION
 UPON COMPLETION OF ASSEMBLY

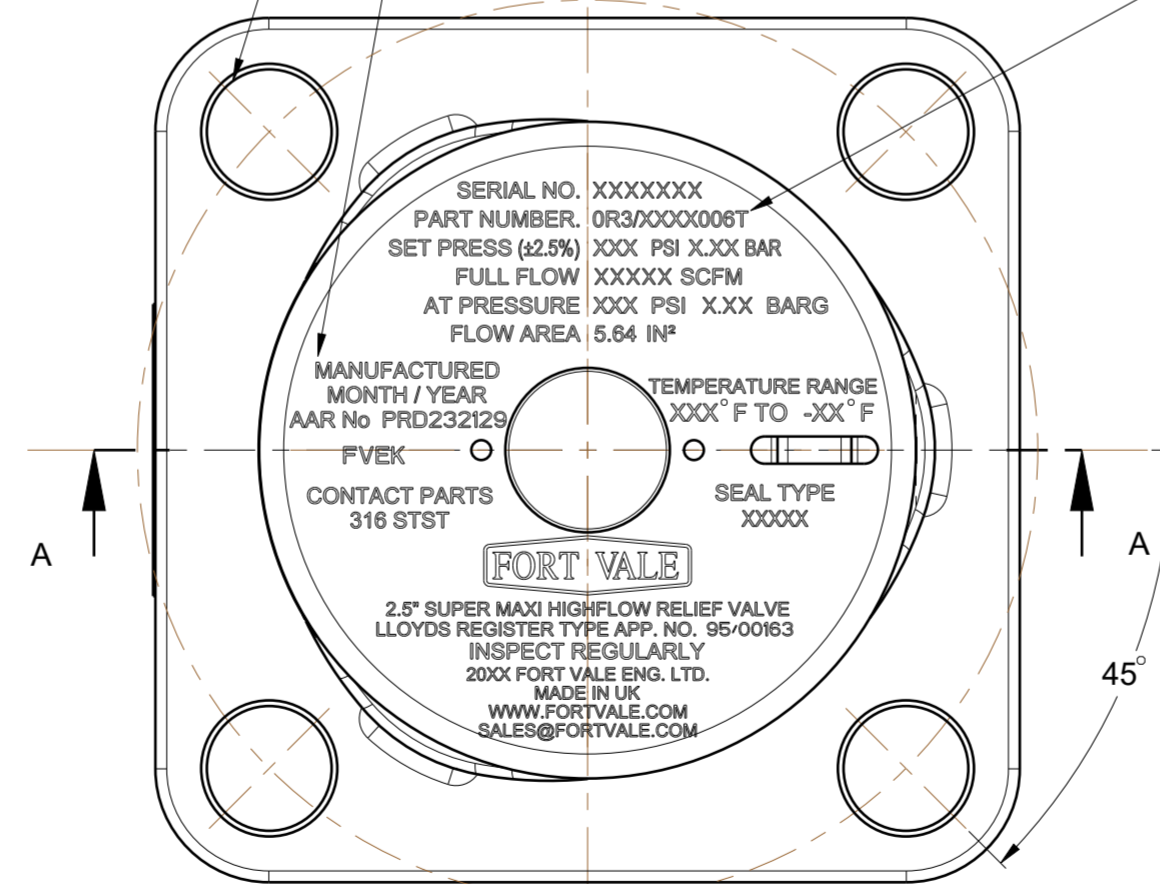

7	XXXX/XXXX	TOP CAP (SEE TABLE 1)	304 STST	1
6	1860/X190XX	COMPOSITE PRESSURE PLATE (SEE TABLES 1&2)	316 STST	1
5	1860/0626	VALVE BODY MACHINED	CF3M	1
4	10978/1	STAINLESS PLUG	304L STST	1
3	6104-XXXX	PRESSURE SPRING (SEE TABLE 1)	17/7 SS	1
2	5121-001	3/16"BSW.3/16"LG SOCKETHEAD	A2-70	1
1	5120-067	RETAINING RING CLIP	316 STST	1
Index	Part Number	Description	Material	Qty

Assembly BOM

SALES@FORTVALE.COM WWW.FORTVALE.COM

ENGLAND, USA, CHINA
NETHERLANDS, SINGAPORE

© FORT VALE ENGINEERING LTD 2023.

DO NOT SCALE- IF IN DOUBT ASK

UNLESS OTHERWISE STATED

ISO9001:2015 REGISTERED FIRM: LKQ4007111

2.5" SUPER MAXI HIGHFLOW R/V

MK3 SUPER MAXI HIGH FLOW

0R3/XXXX006T

0R3/X165006T	1860/0041/5	1860/X19054	6104-1264R	SPRING PAIR	165,0 [11,38]			22286 [10,52]	198,0 [13,66]	24000 [11,33]	214,5 [14,79]	17,2 [7,8]	5,51 [139,9]
0R3/X075006T	1760/0028	1860/X19060	6104-0570	SPRING PAIR	75,0 [5,17]	9564.7 [4,51]	85,0 [5,86]	10131 [4,78]	90,0 [6,21]	11052 [5,22]	97,5 [6,72]	14,3 [6,5]	4,43 [112,5]
PART NUMBER	TOP CAP (ITEM 5)	PRESSURE PLATE (ITEM 7)	INNER PRESSURE SPRINGS	OUTER PRESSURE SPRINGS	SET PRESSURE PSI [BAR]	113% CERTIFIED FULL FLOW SCFM [SM ³ /S]	113% OVER PRESSURE PSI [BAR]	120% CERTIFIED FULL FLOW SCFM [SM ³ /S]	120% OVER PRESSURE PSI [BAR]	130% CERTIFIED FULL FLOW SCFM [SM ³ /S]	130% OVER PRESSURE PSI [BAR]	MASS lb [kg]	HEIGHT A inch [mm]

TABLE 1

DRAWING STATUS		Production	
REVISION	14	SIG	D BAILEY
			22-Nov-23
PRD NUMBER PRD232129 WAS PRD139511			

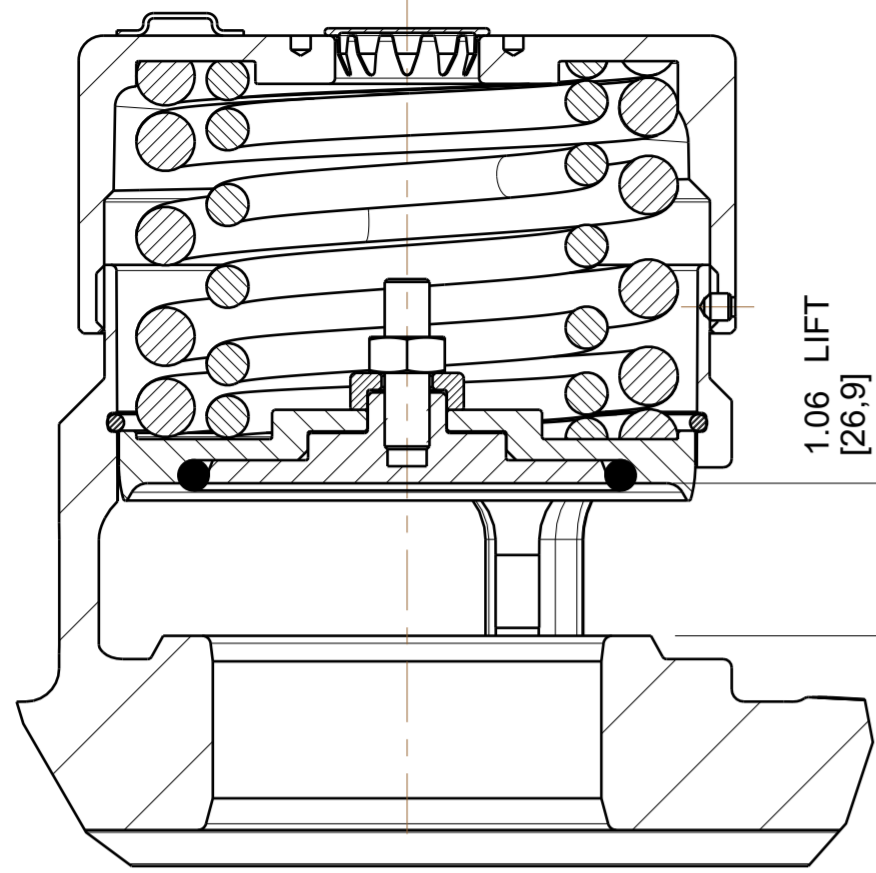

VALVE IN OPEN POSITION
SECTION A-A
SCALE 3:4

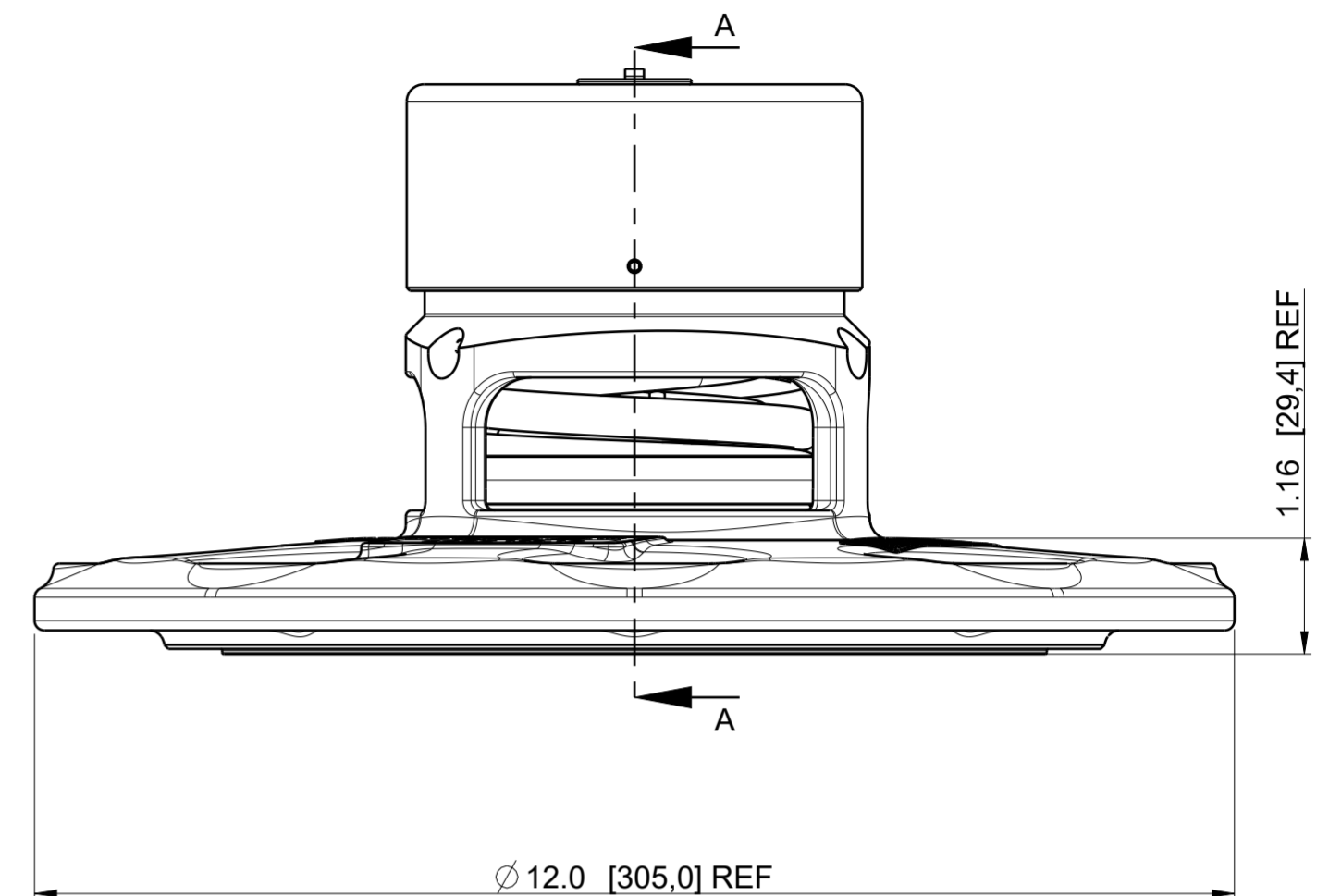
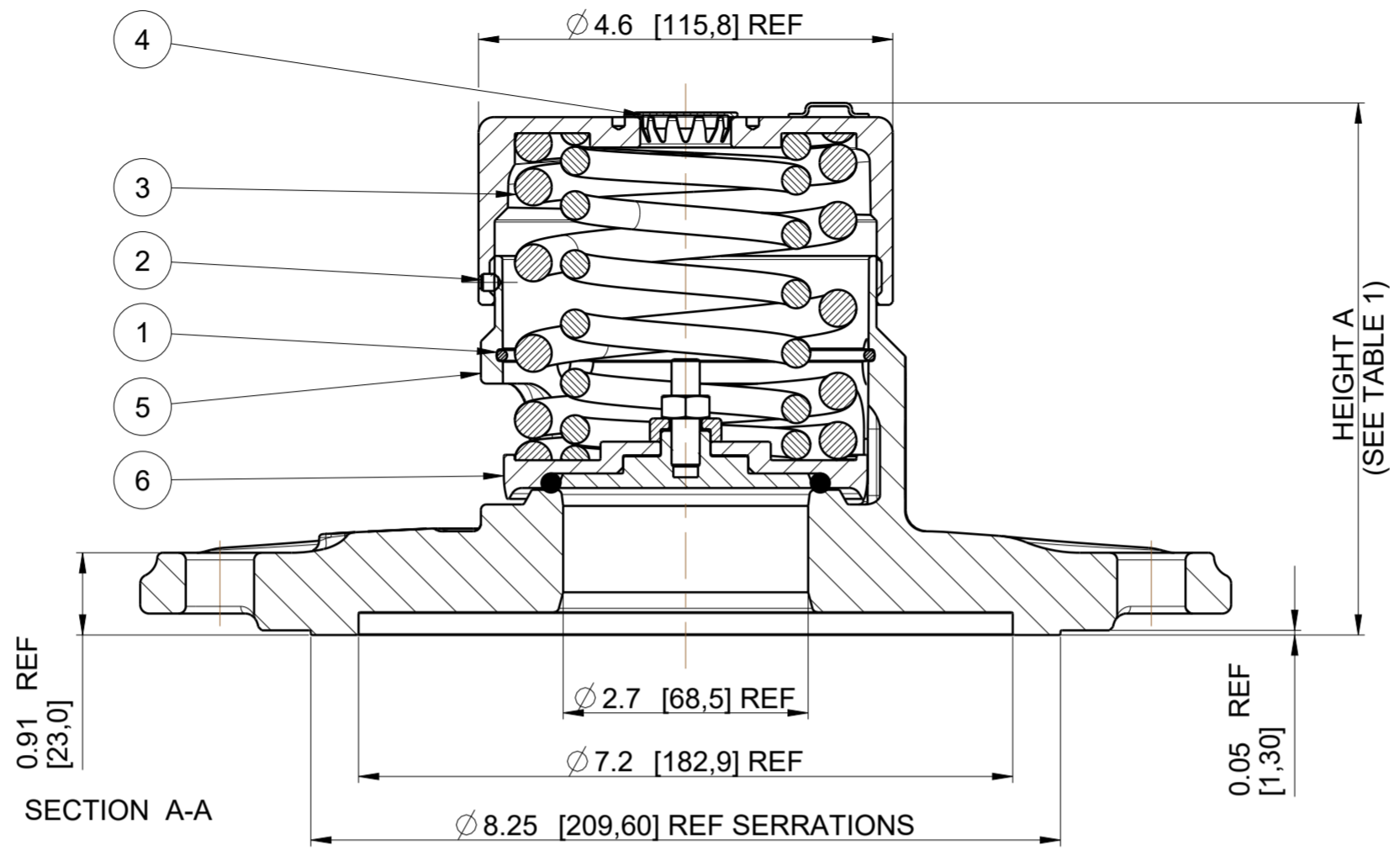

PART NUMBER EXAMPLE :-
OR3/0075006V VALVE DENOTES
65mm RELIEF VALVE SET AT 75 PSIG
PRESSURE SEAL MATERIAL VITON A

AAR APPLICATION NUMBER: PRD232129

MATERIAL MUST CONFORM TO:
ASME SA351 CF8M, ASTM CF8M (YEAR DATE)
ASME SA479 316L, ASTM A479 316L(YEAR DATE)

8 HOLES ϕ 0.75 [19.05] THRO'
EQUISPACED AS SHOWN
ON A 10.3 [260.4] PCD

NOTE!
REPLACE MONTH/YEAR
WITH CURRENT DATE
INFORMATION
E.G. MAY/2016

AFFIX CID TAG
HERE

CAP TO BE LASER MARKED AS SHOWN
WITH X'S TO BE FILLED IN WITH
CORRECT INFORMATION
UPON COMPLETION OF ASSEMBLY

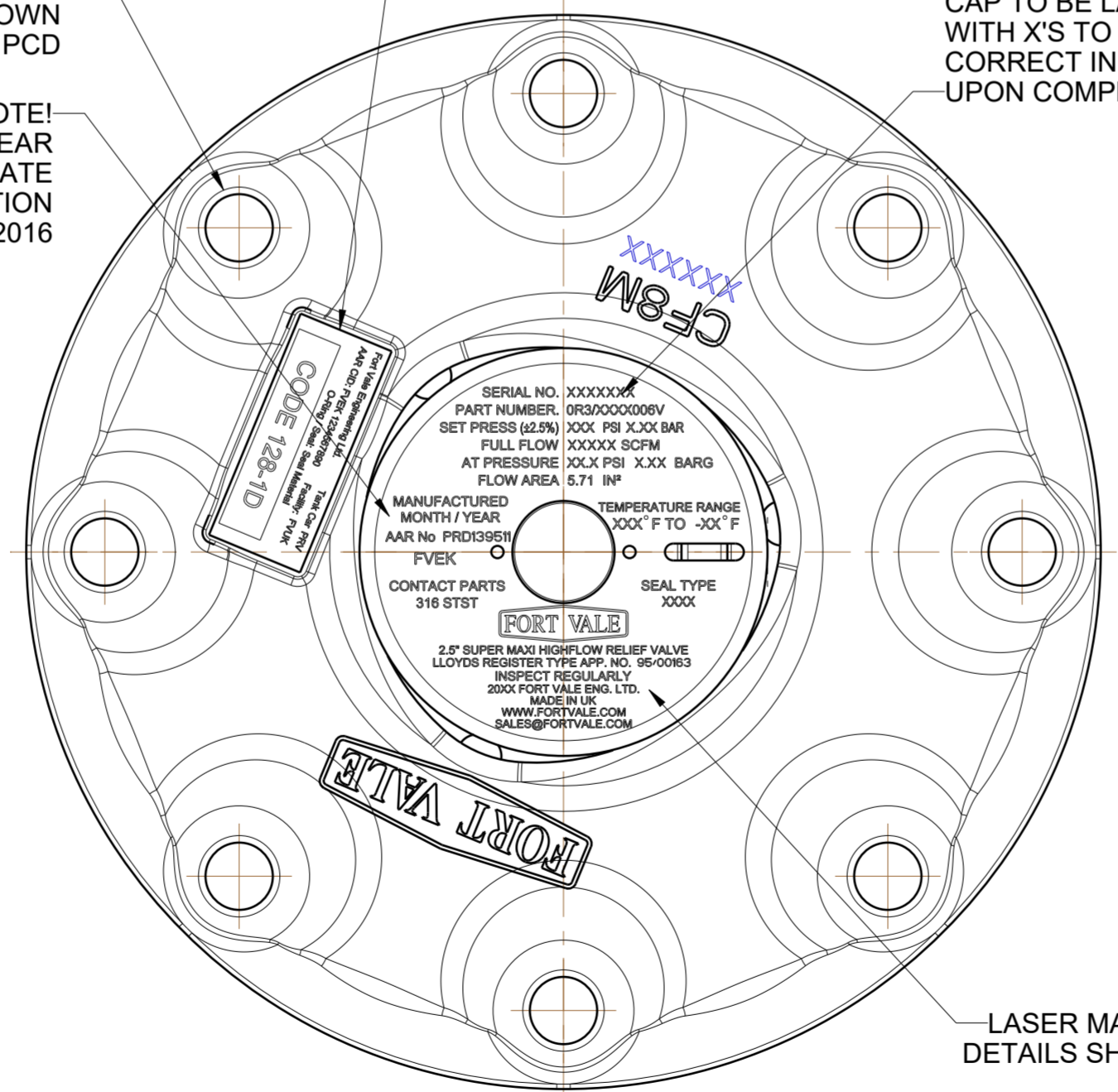

DESIGN CODES: AAR M1002, ASME VIII DIV1
DESIGN PRESSURE (MAWP): 165 PSI (11.38 BAR)
SERVICE TEST PRESSURE : 283 PSI (19.50 BAR)
MAX DESIGN TEMPERATURE: 150° F (66° C)
MIN DESIGN TEMPERATURE: -55° F (-48° C) } FOR METAL PARTS

REFER TO TABLE 2 FOR SEAL TEMPERATURE LIMITATIONS

Index	Part Number	Description	Material	Qty
7	XXXX/XXXX	TOP CAP (SEE TABLE 1)	304 STST	1
6	1860/X190XX	COMPOSITE PRESSURE PLATE (SEE TABLES 1&2)	316 STST	1
5	1860/0628	RAIL MAXI BODY MACHINING	CF8M	1
4	10978/1	STAINLESS PLUG	304L STST	1
3	6104-XXXX	PRESSURE SPRING (SEE TABLE 1)	17/7 SS	1
2	5121-001	3/16"BSW.3/16"LG SOCKETHEAD	A2-70	1
1	5120-067	RETAINING RING CLIP	316 STST	1

OR3/UXXX006V	VITON B (TRELLEBORG 4273B)	1860/U190XX	-15° C (+5° F)	150° C (302° F)
OR3/DXX006V	WHITE EPDM (FOOD GRADE)	1860/D190XX	-50° C (-58° F)	150° C (302° F)
OR3/WXX006V	WHITE BUNA N (FOOD GRADE)	1860/W190XX	-30° C (-22° F)	100° C (212° F)
OR3/SXX006V	VITON GF-S (PEROXIDE CURED)	1860/S190XX	-20° C (-4° F)	150° C (302° F)
OR3/TXX006V	FORTYT PFA OUTER/SILICON CORE	1860/T190XX	-55° C (-67° F)	150° C (302° F)
OR3/NXX006V	WHITE NEOPRENE (FOOD GRADE)	1860/Y190XX	-30° C (-22° F)	100° C (212° F)
OR3/HXX006V	BLACK EPDM (PEROXIDE CURED)	1860/M190XX	-46° C (-50° F)	121° C (250° F)
OR3/GXX006V	VITON GFLT	1860/G190XX	-25° C (-13° F)	150° C (302° F)
OR3/FXX006V	BLACK NEOPRENE	1860/Q190XX	-45° C (-49° F)	100° C (212° F)
OR3/EXXX006V	VITON GF-S (TRELLEBORG CS5350)	1860/P190XX	-20° C (-4° F)	150° C (302° F)
OR3/CXX006V	CHEMRAZ 505	1860/C190XX	-30° C (-22° F)	150° C (302° F)
OR3/BXX006V	VITON B (DUPONT)	1860/B190XX	-15° C (+5° F)	150° C (302° F)
OR3/AXX006V	AFLAS	1860/T190XX	-30° C (-22° F)	150° C (302° F)
OR3/9XX006V	EPDM	1860/E190XX	-50° C (-58° F)	150° C (302° F)
OR3/7XX006V	PERFLUOROELASTOMER	1860/K190XX	-15° C (+5° F)	150° C (302° F)
OR3/4XX006V	BLACK BUNA N (NITRILE)	1860/N190XX	-30° C (-22° F)	100° C (212° F)
OR3/3XX006V	KALREZ 6375	1860/R190XX	-15° C (+5° F)	150° C (302° F)
OR3/1XX006V	FORTYT FEP OUTER/SILICON CORE	1860/F190XX	-55° C (-67° F)	150° C (302° F)
OR3/0XX006V	VITON A	1860/V190XX	-20° C (-4° F)	150° C (302° F)

TABLE 2

PART NUMBER	TOP CAP (ITEM 5)	PRESSURE PLATE (ITEM 7)	INNER PRESSURE SPRINGS	OUTER PRESSURE SPRINGS	SET PRESSURE PSI [BAR]	113% CERTIFIED FULL FLOW SCFM [SM ³ /S]	113% OVER PRESSURE PSI [BAR]	120% CERTIFIED FULL FLOW SCFM [SM ³ /S]	120% OVER PRESSURE PSI [BAR]	130% CERTIFIED FULL FLOW SCFM [SM ³ /S]	130% OVER PRESSURE PSI [BAR]	MASS lb [kg]	HEIGHT A inch [mm]
OR3/X165006V	1860/0041/5	1860/X19054	6104-1264R	SPRING PAIR	165.0 [11.38]			22286 [10.52]	198.0 [13.66]	24000 [11.33]	214.5 [14.79]	33.7 [15.3]	5.86 [148.8]
OR3/X075006V	1760/0028	1860/X19060	6104-0570	SPRING PAIR	75.0 [5.17]	9564.7 [4.51]	85.0 [5.86]	10131 [4.78]	90.0 [6.21]	11052 [5.22]	97.5 [6.72]	30.7 [13.9]	4.86 [123.4]

TABLE 1

FORT VALE SALES@FORTVALE.COM WWW.FORTVALE.COM

ENGLAND, USA, CHINA
NETHERLANDS, SINGAPORE

© FORT VALE ENGINEERING LTD 2023. DO NOT SCALE - IF IN DOUBT ASK

UNLESS OTHERWISE STATED FIRST ANGLE PROJECTION MATERIAL: CF8M

X.X ±0.5	SURFACE FINISH 3.2um MAX	ISO9001:2015 REGISTERED FIRM: LRQ4007111	SCALE: NTS	MASS: (SEE TABLE 1)
X.XX ±0.25	CORNER RADIUS 0.8		CHECKED	DVN: 38739
X.XXX ±0.125	CORNER CHAMFER 1.0 X 45°		SHEET 1 OF 1	
ANGLES ±0.5°	REMOVE ALL BURRS AND SHARP EDGES	DRAWN BY: D BAILEY		DATE: 07-Jun-16

DESCRIPTION: 65mm SUPERMAXI HIGHFLOW R/V

TYPE: MK3 SUPER MAXI HIGH FLOW

DRG.NO. OR3/XXXX006V

DRAWING STATUS		Production	
REVISION	03	SIG	D BAILEY
PRD NUMBER PRD232129 WAS PRD139511, BODY CASTING		21-Nov-23	
UPDATED, CID TAG ADDED			

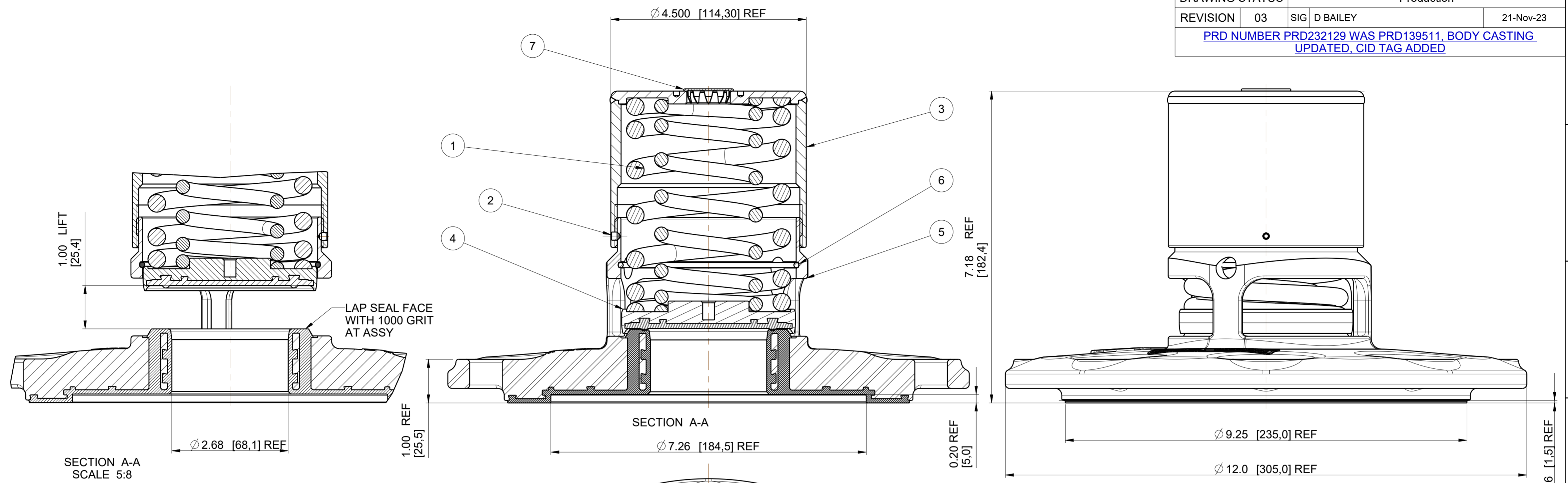

PART NUMBER EXAMPLE :-
 0U3/P165006A VALVE DENOTES
 65mm RELIEF VALVE SET AT 165 PSIG
 PRESSURE SEAL MATERIAL PFA

AAR APPLICATION NUMBER: PRD232129
 AAR STATION FVEK
 MATERIAL MUST CONFORM TO
 ASME SA351 CF3M, ASTM A351 CF3M(YEAR DATE)

NOTE!
ALL WETTED AREAS
PFA COATED
SPRINGS HALAR COATED

DESIGN CODE : ASME VIII DIV 1
 DESIGN PRESSURE (MAWP) : 165psig 11.38barg
 SERVICE TEST PRESSURE : 248psig 17.1barg
 MAX DESIGN TEMPERATURE : 302°F (150°C)
 MIN DESIGN TEMPERATURE : -67°F (-55°C)

8 HOLES Ø0.75 [19,05] THRO
 EQUI-SPACED AS SHOWN
 ON A 10.3 [260,4] PCD

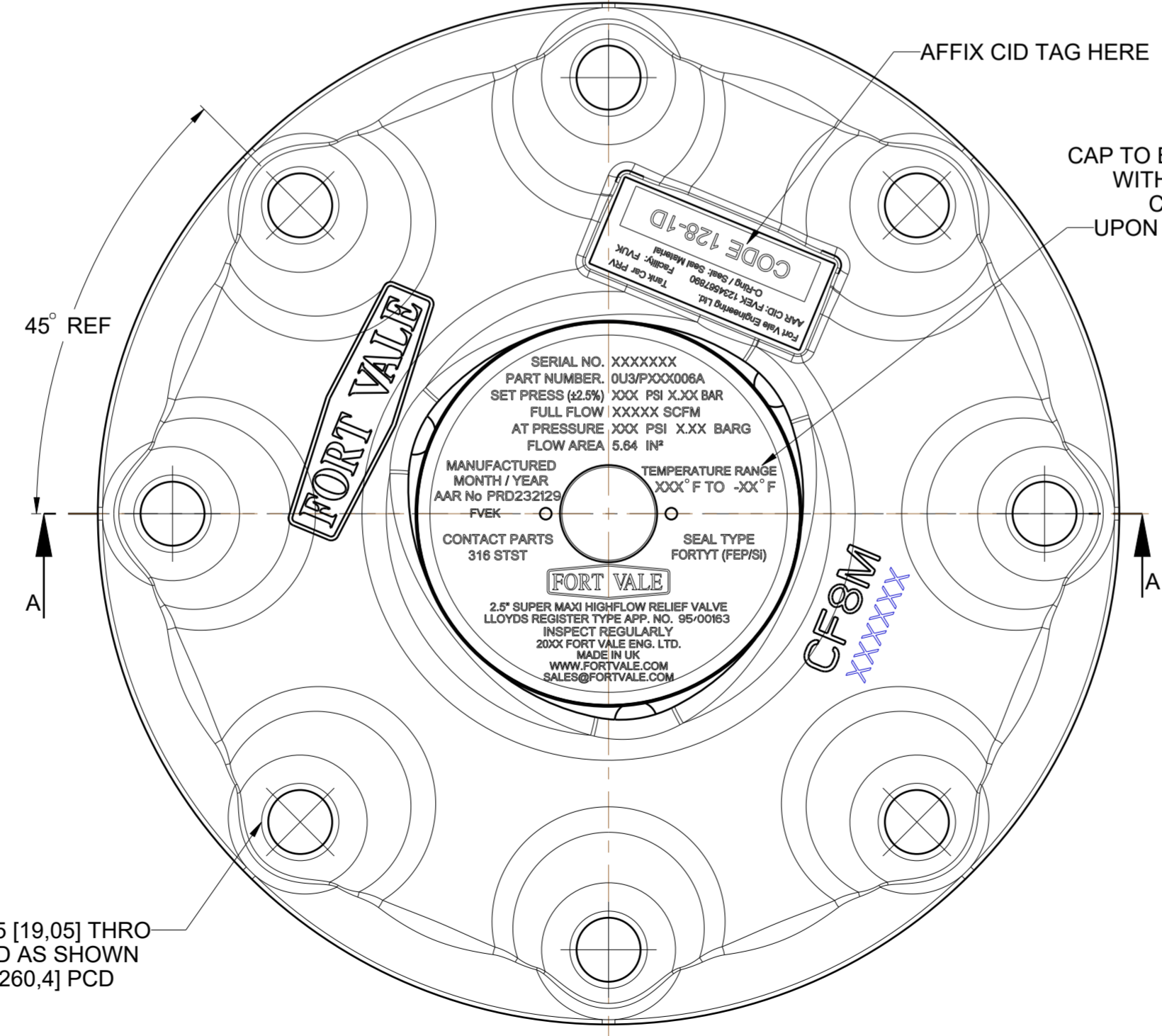

AFFIX CID TAG HERE
 CAP TO BE LASER MARKED AS SHOWN
 WITH X'S TO BE FILLED IN WITH
 CORRECT INFORMATION
 UPON COMPLETION OF ASSEMBLY

Index	Part Number	Description	Material	Qty
7	10978/1	STAINLESS PLUG	ST ST	1
6	5120-067	RETAINING RING CLIP	316 STST	1
5	1860/0629/U	PFA LINED BODY BLANK	CF8M / PFA	1
4	1860/P0XX	LINED PRESSURE PLATE (SEE TABLE)	316/316L STST / PFA	1
3	1860/XXXX	TOP CAP (SEE TABLE)	316L STST	1
2	5121-001	3/16"BSW.3/16"LG SOCKETHEAD	A2-70	1
1	6104-XXXX	PRESSURE SPRING (SEE TABLE)	HALAR COATED 17/7 SS	1

Assembly BOM

FORT VALE SALES@FORTVALE.COM WWW.FORTVALE.COM
 ENGLAND, USA, CHINA
 NETHERLANDS, SINGAPORE

© FORT VALE ENGINEERING LTD 2023. DO NOT SCALE- IF IN DOUBT ASK

UNLESS OTHERWISE STATED FIRST ANGLE PROJECTION MATERIAL: VARIOUS

X.X ±0.5	SURFACE FINISH 3.2um MAX	ISO9001:2015 REGISTERED FIRM: LRQ4007111	SCALE: 5:8	MASS: SEE TABLE
X.XX ±0.25	CORNER RADII 0.8		CHECKED	DVN: 38739
X.XXX ±0.125	CORNER CHAMFER 1.0 X 45°		SHEET 1 OF 1	
ANGLES ±0.5°	REMOVE ALL BURRS AND SHARP EDGES	DRAWN BY: D BAILEY		DATE: 11-OCT-16

DESCRIPTION: 2.5" SUPERMAXI HIGHFLOW R/V
 TYPE: MK3 SUPER MAXI HIGH FLOW

DRG.NO. 0U3/PXXX006A

0U3/P165006A	1860/0049/5	1860/P085	6104-1264RL	SPRING PAIR	165,0 [11,38]	22286.3 [10.52]	198,0 [13,66]	24000 [11.33]	214.5 [14.79]	35,2 [16,0]
PART NUMBER	TOP CAP (ITEM 5)	PRESSURE PLATE (ITEM 7)	INNER SPRING	OUTER SPRING	SET PRESSURE PSI [BAR]	120% CERTIFIED FULL FLOW SCFM [sm ³ /S]	120% OVER PRESSURE PSI [BAR]	130% CERTIFIED FULL FLOW SCFM [sm ³ /S]	130% OVER PRESSURE PSI [BAR]	MASS lb [kg]

DRAWING STATUS		PPAP		
REVISION	05	SIG	D BAILEY	22-Nov-23
PRD NUMBER PRD232129 WAS PRD139511				

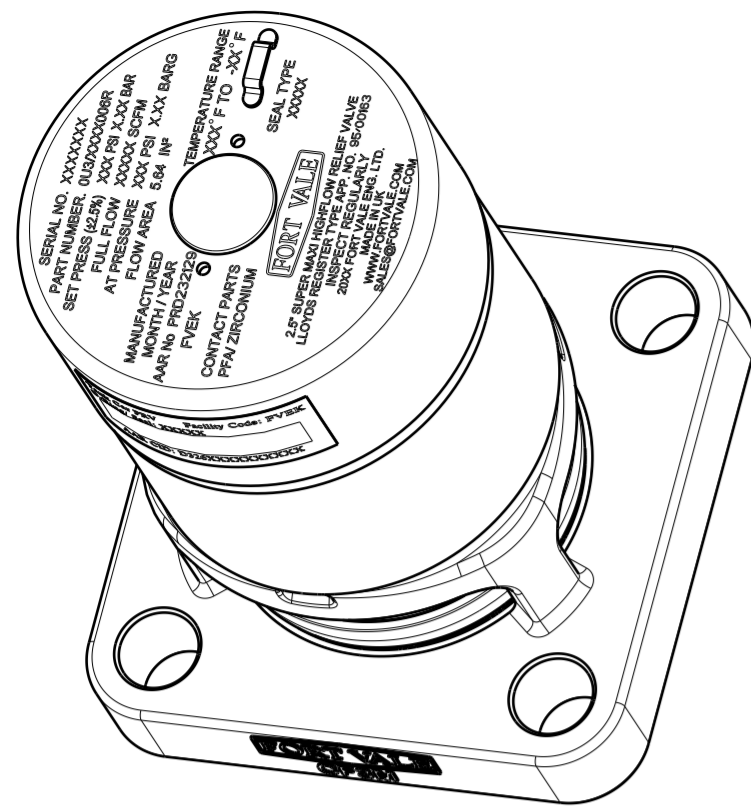

SCALE 1:2

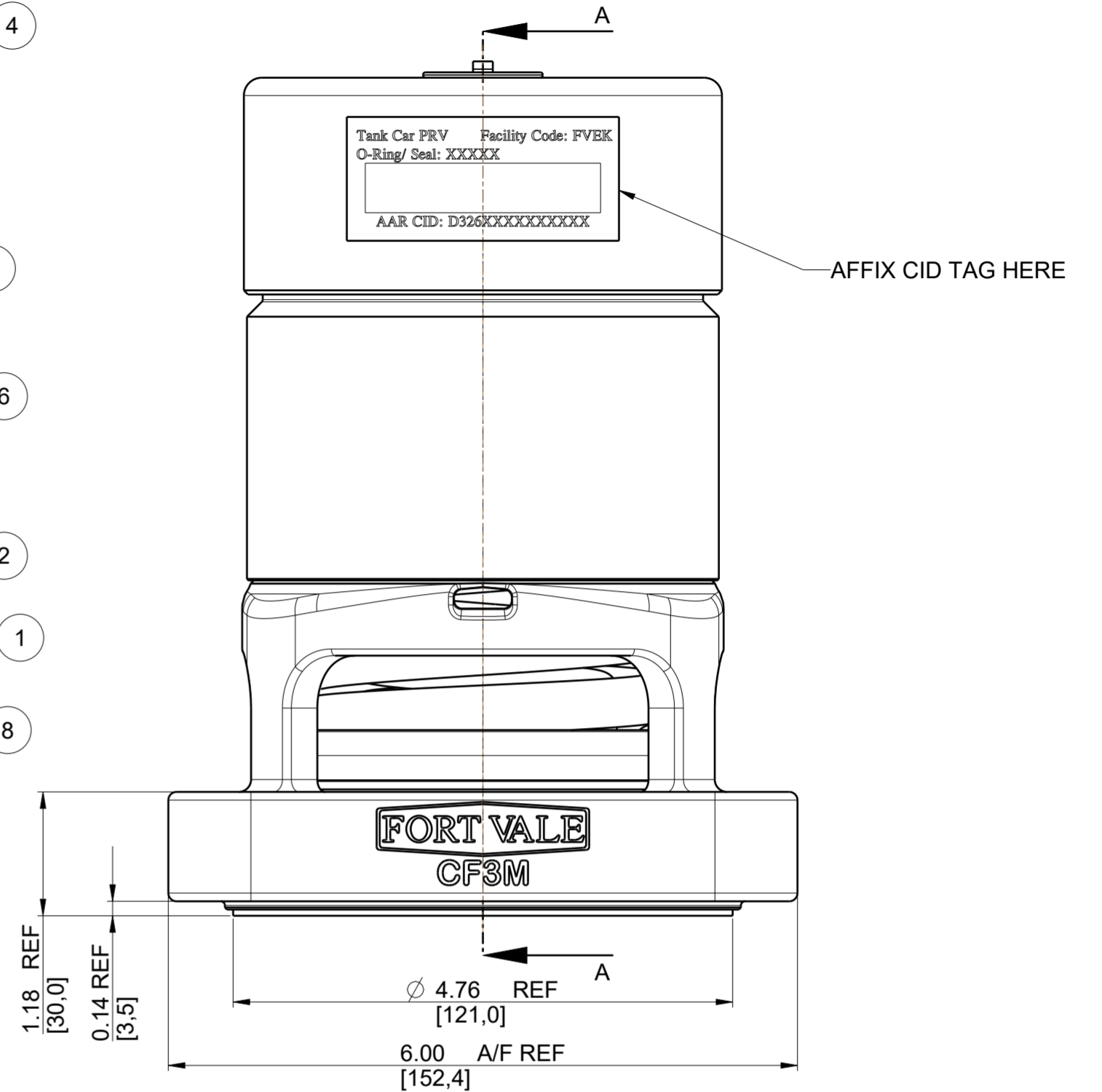
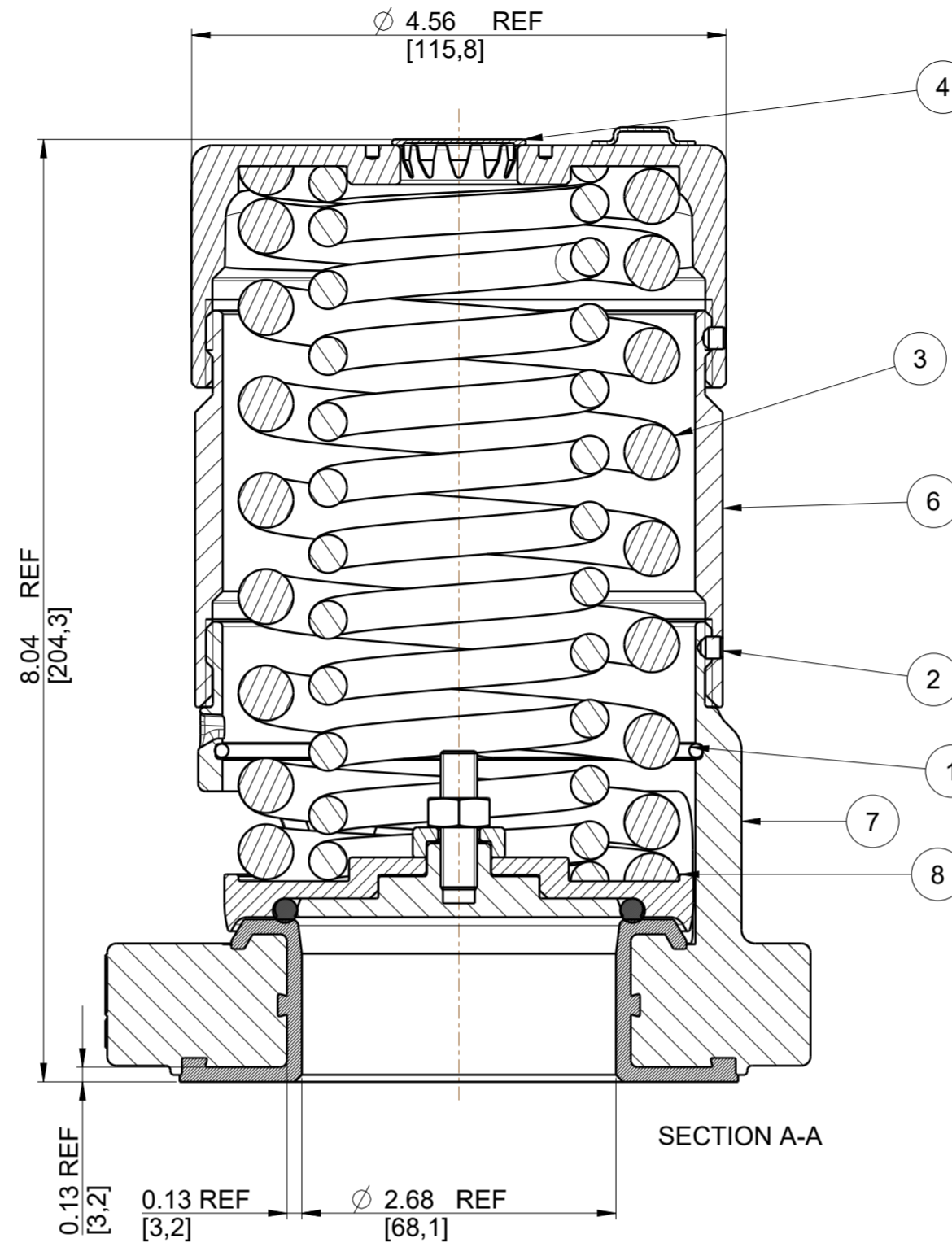
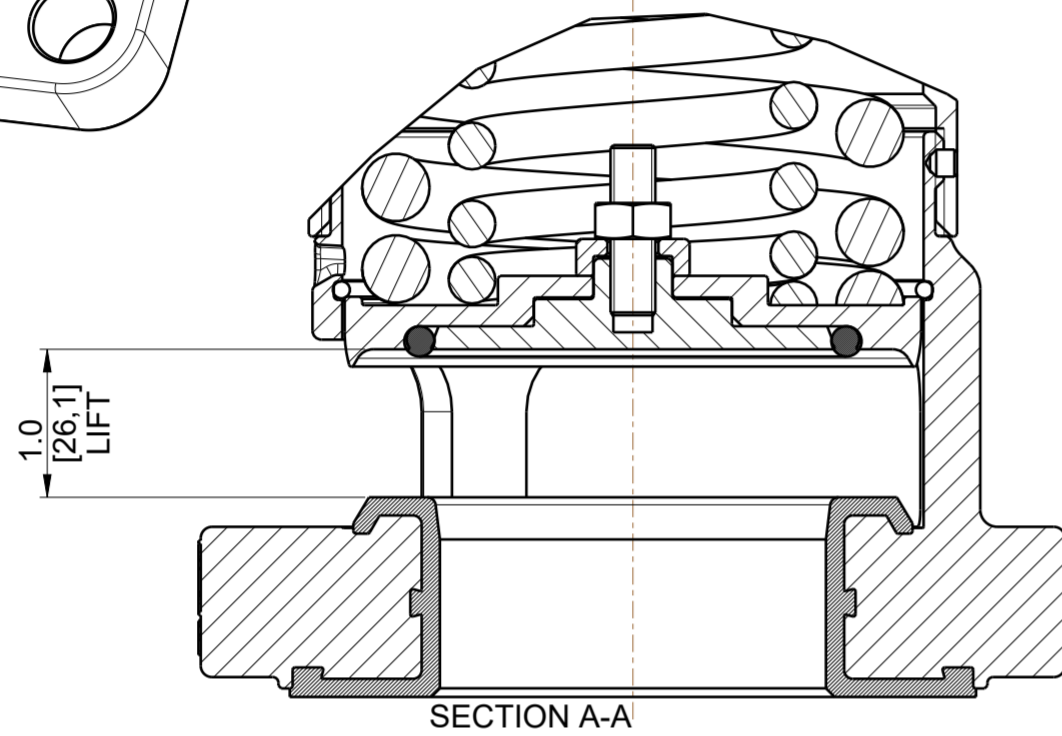

NOTE! WETTED AREAS
BODY = PFA COATED
PRESSURE PLATE = ZIRCONIUM
SPRINGS INCONEL X750

CAP TO BE LASER MARKED AS SHOWN WITH X'S TO BE FILLED IN WITH CORRECT INFORMATION UPON COMPLETION OF ASSEMBLY

NOTE!
 REPLACE MONTH/YEAR WITH CURRENT DATE INFORMATION
 E.G. APRIL/2024

4 HOLES \varnothing 0.87 [22.0] THRO' EQUI-SPACED AS SHOWN ON A 6.25 [158.8] PCD

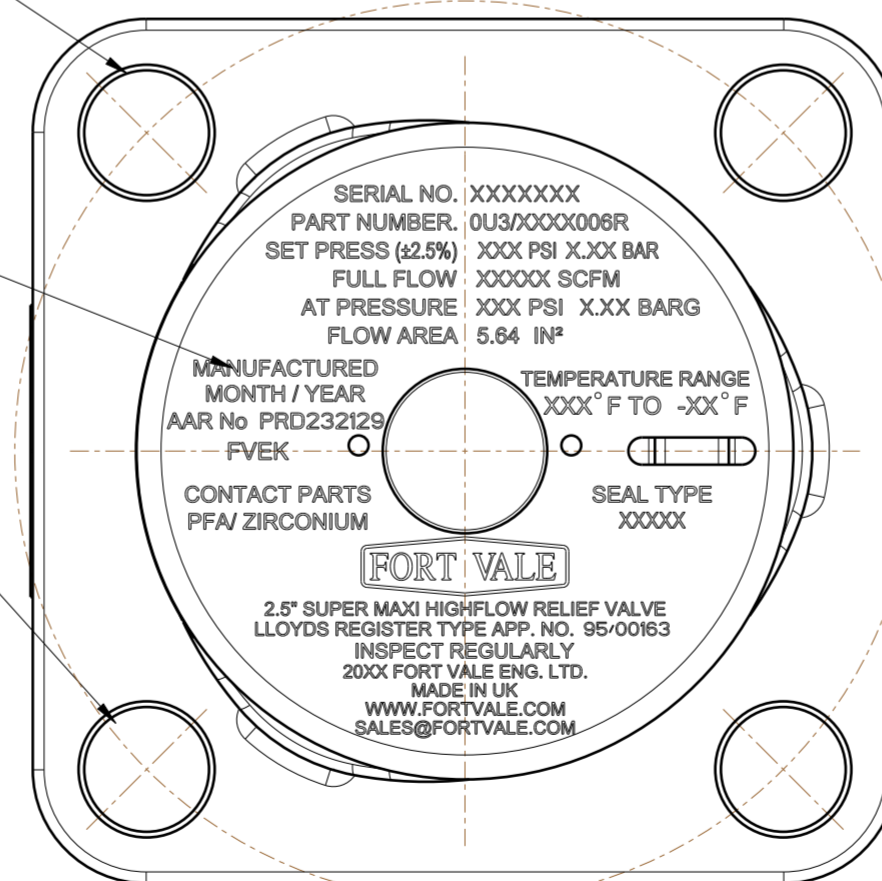

PART NUMBER EXAMPLE :-
 0U3/0165006R VALVE DENOTES
 65mm RELIEF VALVE SET AT 165 PSIG
 PRESSURE SEAL MATERIAL VITON A

AAR APPLICATION NUMBER: PRD232129

DESIGN CODE: ASME VIII DIV1
 COLD RATING PRESSURE (CWP) : 165,0 PSI (11,38 BAR)
 SERVICE TEST PRESSURE : 277,0 PSI (19,10 BAR)
 MAX DESIGN TEMPERATURE : 302 °F (150 °C)
 MIN DESIGN TEMPERATURE : -40 °F (-40 °C) } FOR METAL PARTS

REFER TO TABLE 2 FOR SEAL TEMPERATURE LIMITATIONS

0U3/FXXX006R	1860/Q191XXZ	ZIRCONIUM / 316 STST	BLACK NEOPRENE	-50°F (-45°C)	212°F (100°C)
0U3/EXXX006R	1860/P191XXZ	ZIRCONIUM / 316 STST	VITON GF-S (TRELLEBORG MATL. CS5350)	-4°F (-20°C)	302°F (150°C)
0U3/BXXX006R	1860/B191XXZ	ZIRCONIUM / 316 STST	VITON B (DUPONT)	+5°F (-15°C)	302°F (150°C)
0U3/OXXX006R	1860/V191XXZ	ZIRCONIUM / 316 STST	VITON A	-4°F (-20°C)	302°F (150°C)

VALVE PART NUMBER	VALVE PLATE PART NUMBER	PLATE MATERIAL	SEAL MATERIAL	SEAL MIN TEMP	SEAL MAX TEMP								
0U3/X075006R	1860/0041/A56	1860/X19155Z	6104-0570I	SPRING PAIR	75,0 [5,17]	10131 [2,30]	90,0 [6,21]	11052 [5,22]	97,5 [6,72]	15,2 (6,9)	5,04 (128,0)		
0U3/X165006R	1860/0041/949	1860/X19148Z	6104-1264RI	SPRING PAIR	165,0 [11,38]	9564.7 [4,51]	85,0 [5,86]	22286 [4,67]	198,0 [13,66]	24000 [11,33]	214,5 [14,79]	22,1 (10,0)	7,99 (203,0)
PART NUMBER	TOP CAP (ITEM 6)	PRESSURE PLATE (ITEM 8)	INNER PRESSURE SPRINGS	OUTER PRESSURE SPRINGS	SET PRESSURE PSI [BAR]	113% CERTIFIED FULL FLOW SCFM [SM ³ /S]	113% OVER PRESSURE PSI [BAR]	120% CERTIFIED FULL FLOW SCFM [SM ³ /S]	120% OVER PRESSURE PSI [BAR]	130% CERTIFIED FULL FLOW SCFM [SM ³ /S]	130% OVER PRESSURE PSI [BAR]	MASS lb [kg]	HEIGHT A inch [mm]

TABLE 1

8	1860/X191XXZ	PRESSURE PLATE (SEE TABLE 2)	VARIOUS	1
7	1860/0625P	PFA LINED SUPER MAXI BODY MACHINING	CF3M/PFA	1
6	1860/0094	EXTENSION TUBE	316L STST	1
5	1860/0041/XXX	TOP CAP (SEE TABLE 1)	CF8	1
4	10978/1	STAINLESS PLUG	ST ST	1
3	6104-XXXXRI	PRESSURE SPRING (SEE TABLE 1)	INCONEL X750	1
2	5121-001	3/16"BSW.3/16"LG SOCKETHEAD	A2-70	2
1	5120-067	RETAINING RING CLIP	316 STST	1
Index	Part Number	Description	Material	Qty

Assembly BOM



SALES@FORTVALE.COM WWW.FORTVALE.COM

ENGLAND, USA, CHINA
NETHERLANDS, SINGAPORE

© FORT VALE ENGINEERING LTD 2023.

UNLESS OTHERWISE STATED		DO NOT SCALE- IF IN DOUBT ASK	
FIRST ANGLE PROJECTION		MATERIAL: CF3M/PFA	
X.X ±0.5	SURFACE FINISH 3.2um MAX	ISO9001:2015 REGISTERED FIRM: LKQ4007111	SCALE: 3:4
X.XX ±0.25	CORNER RADII 0.8		MASS: 10,02 kg
X.XXX ±0.125	CORNER CHAMFER 1.0 X 45°		CHECKED DVN: 38739
ANGLES ±0.5°	REMOVE ALL BURRS AND SHARP EDGES		
DESCRIPTION		SHEET 1 OF 1	
2.5" SUPERMAXI R/V		DRAWN BY: D BAILEY	
		DATE: 17-Oct-19	
TYPE		DRG.NO.	
MK3 SUPER MAXI HIGH FLOW		0U3/XXXX006R	

MK3 SUPER MAXI HIGH FLOW

0U3/XXXX006R

DRAWING STATUS		PPAP	
REVISION	05	SIG	D BAILEY
		22-Nov-23	
PRD NUMBER PRD232129 WAS PRD139511			

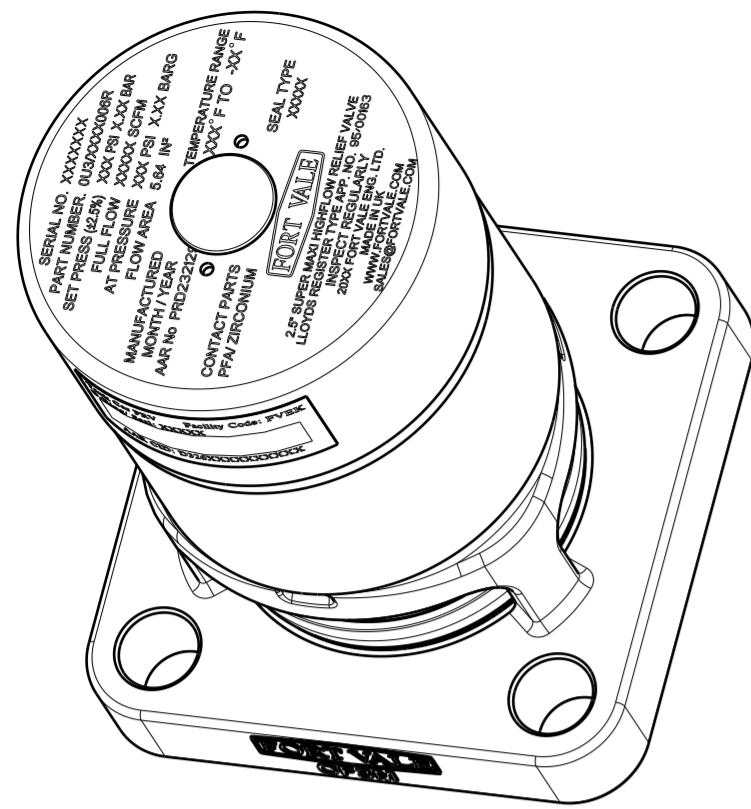

SCALE 1:2

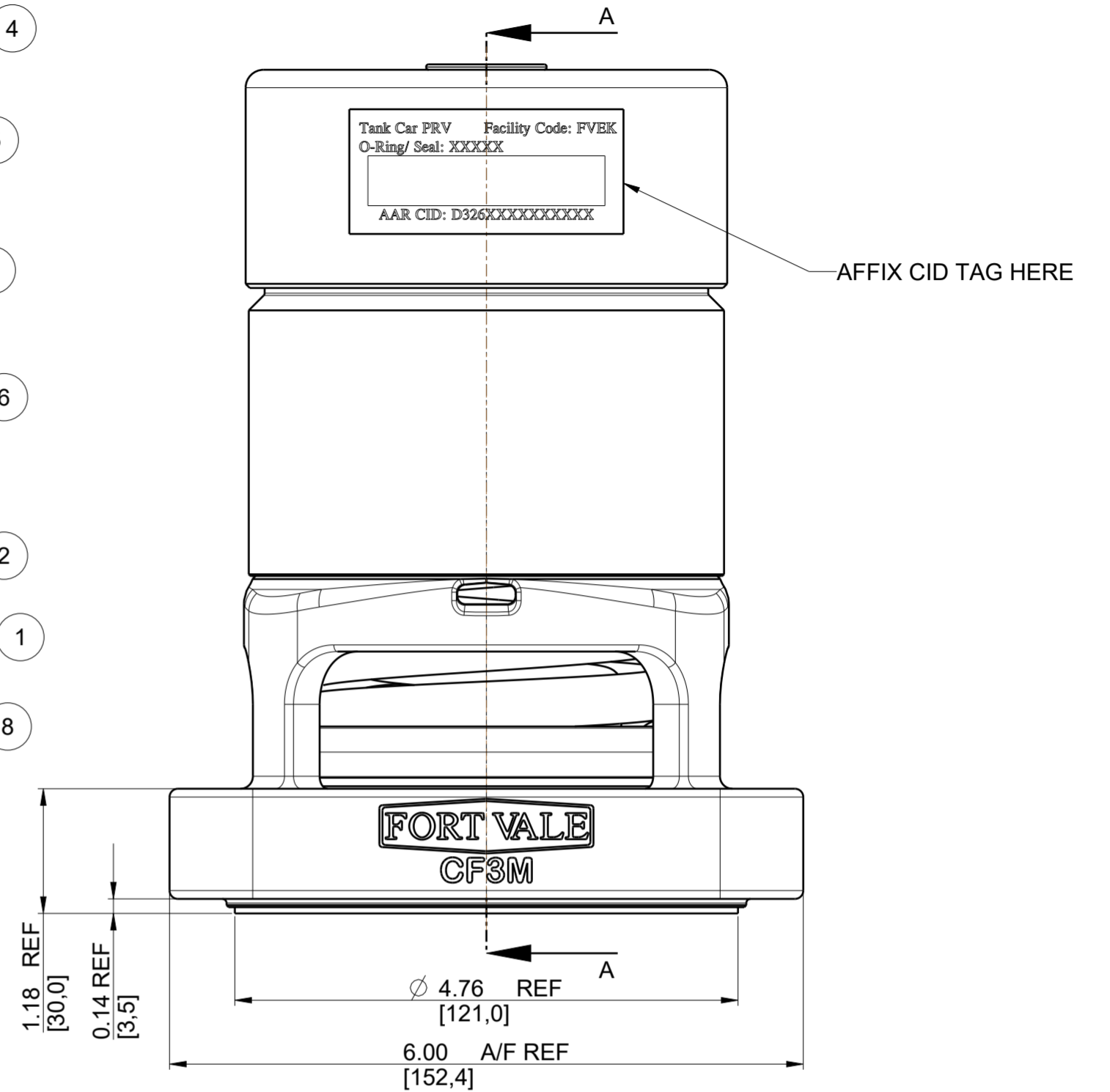
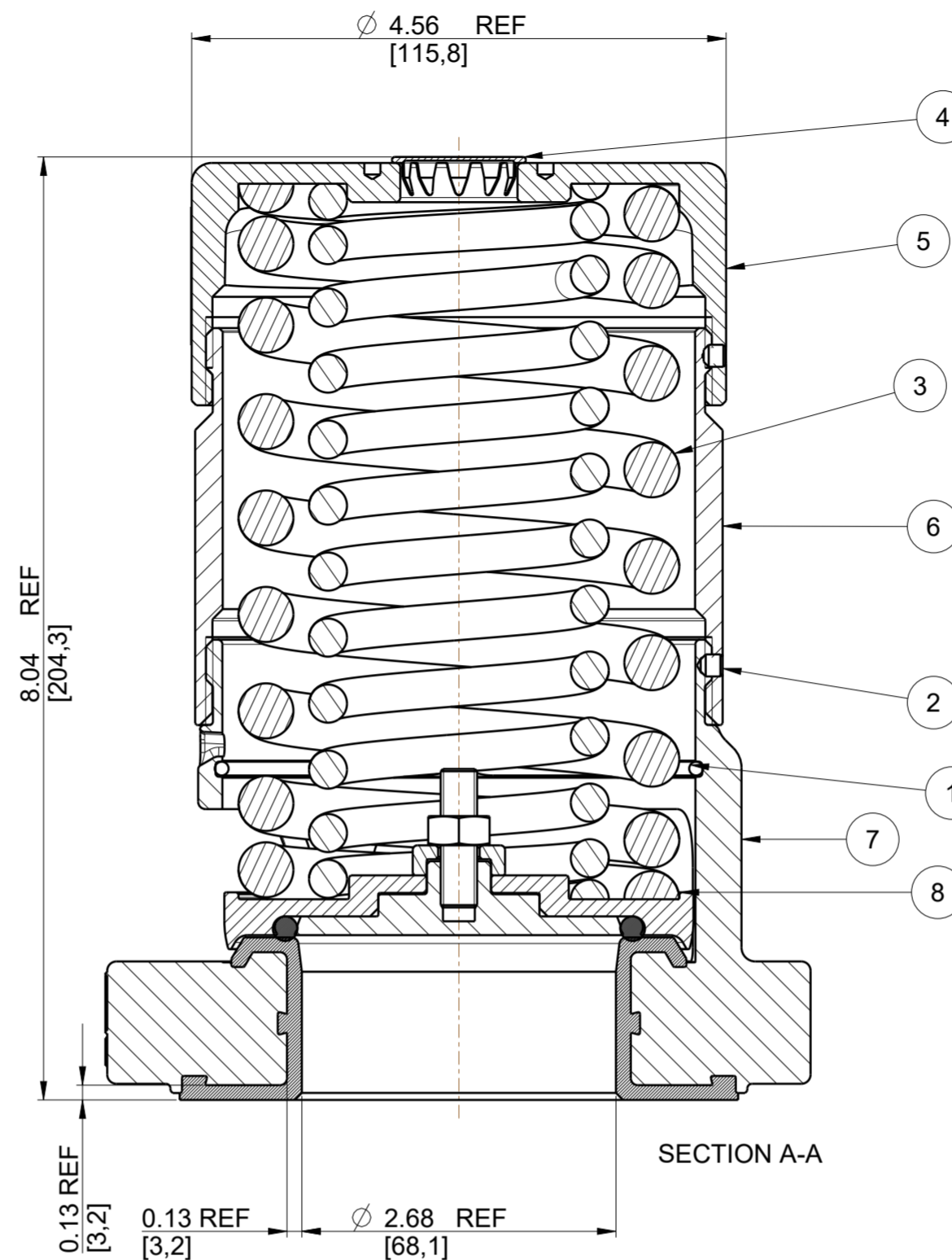
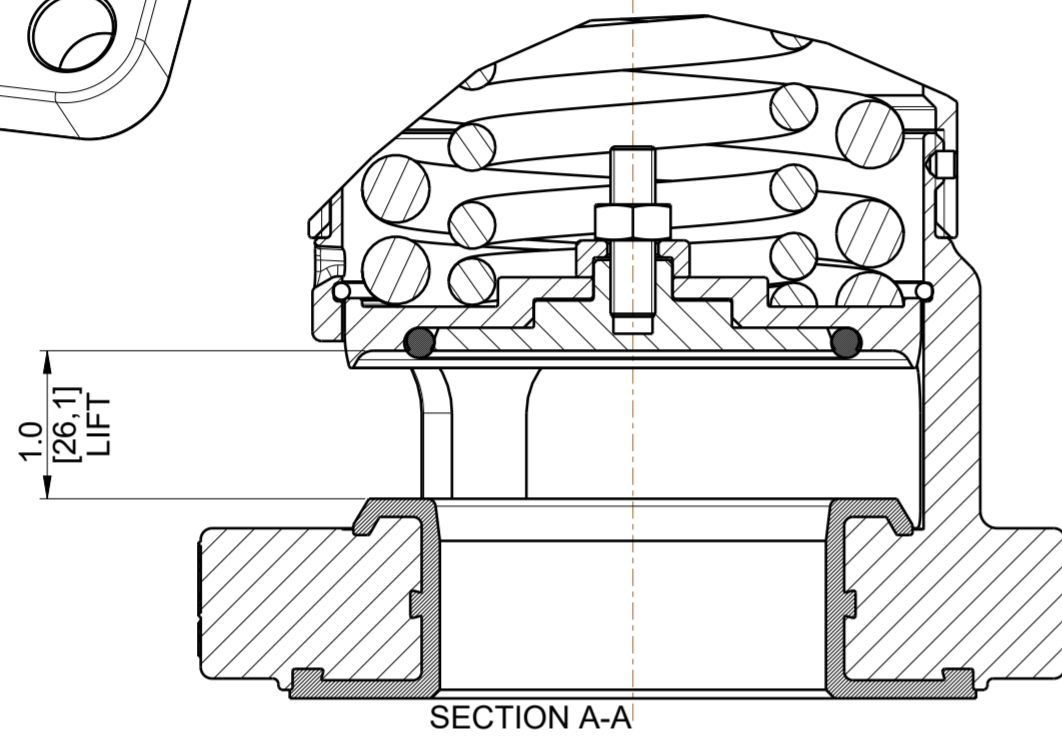

NOTE! WETTED AREAS
BODY = PFA COATED
PRESSURE PLATE = ZIRCONIUM
SPRINGS INCONEL X750

CAP TO BE LASER MARKED AS SHOWN WITH X'S TO BE FILLED IN WITH CORRECT INFORMATION UPON COMPLETION OF ASSEMBLY

NOTE!
 REPLACE MONTH/YEAR WITH CURRENT DATE INFORMATION
 E.G. APRIL/2024

4 HOLES Ø 0.87 [22.0] THRO' EQUI-SPACED AS SHOWN ON A 6.25 [158.8] PCD

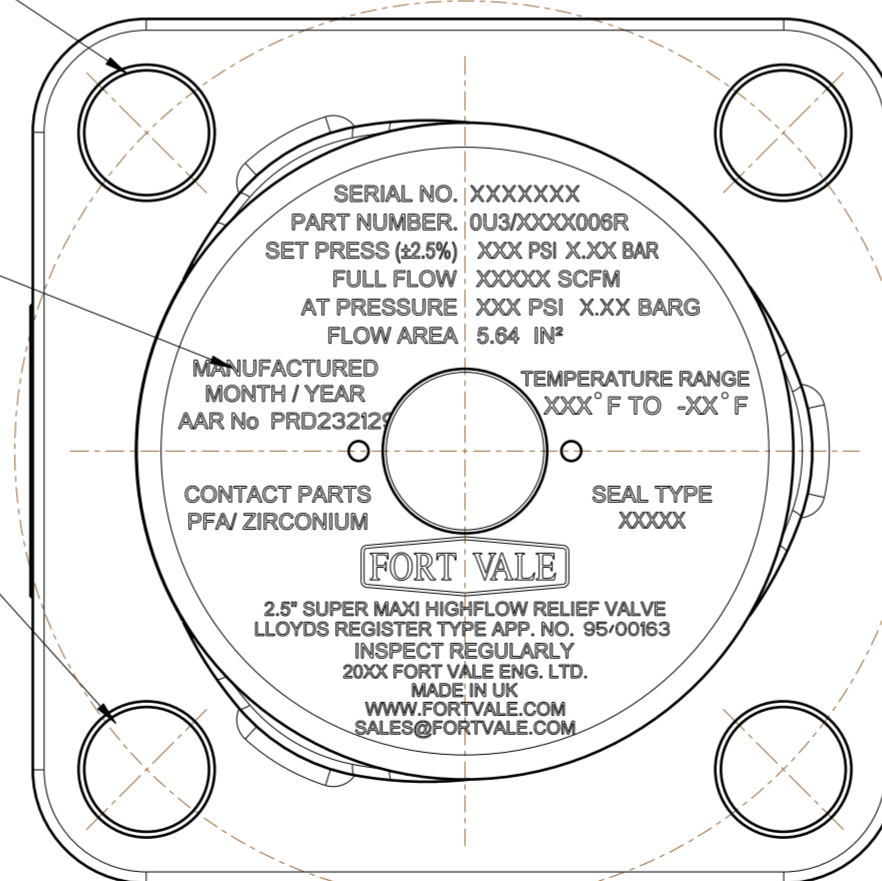

PART NUMBER EXAMPLE :-
 0U3/0165006R VALVE DENOTES
 65mm RELIEF VALVE SET AT 165 PSIG
 PRESSURE SEAL MATERIAL VITON A

AAR APPLICATION NUMBER: PRD232129

DESIGN CODE: ASME VIII DIV1
 COLD RATING PRESSURE (CWP) : 165,0 PSI (11,38 BAR)
 SERVICE TEST PRESSURE : 277,0 PSI (19,10 BAR)
 MAX DESIGN TEMPERATURE : 302° F (150° C)
 MIN DESIGN TEMPERATURE : -40° F (-40° C) } FOR METAL PARTS

REFER TO TABLE 2 FOR SEAL TEMPERATURE LIMITATIONS

0U3/FXXX006R	1860/Q191XXZ	ZIRCONIUM / 316 STST	BLACK NEOPRENE	-50°F (-45°C)	212°F (100°C)
0U3/EXXX006R	1860/P191XXZ	ZIRCONIUM / 316 STST	VITON GF-S (TRELLEBORG MATL. CS5350)	-4°F (-20°C)	302°F (150°C)
0U3/BXXX006R	1860/B191XXZ	ZIRCONIUM / 316 STST	VITON B (DUPONT)	+5°F (-15°C)	302°F (150°C)
0U3/OXXX006R	1860/V191XXZ	ZIRCONIUM / 316 STST	VITON A	-4°F (-20°C)	302°F (150°C)

VALVE PART NUMBER	VALVE PLATE PART NUMBER	PLATE MATERIAL	SEAL MATERIAL	SEAL MIN TEMP	SEAL MAX TEMP								
0U3/X075006R	1860/0041/855	1860/X190XX	6104-0570I	SPRING PAIR	75.0 [5,17]	10131 [2,30]	90,0 [6,21]	11052 [5,22]	97,5 [6,72]	19,5 (8,9)	5,04 (128,0)		
0U3/X165006R	1860/0041/949	1860/X190XX	6104-1264RI	SPRING PAIR	165,0 [11,38]	9564.7 [4,51]	85,0 [5,86]	22286 [4,67]	198,0 [13,66]	24000 [11,33]	214,5 [14,79]	21,9 (9,9)	7,99 (203,0)
PART NUMBER	TOP CAP (ITEM 6)	PRESSURE PLATE (ITEM 8)	INNER PRESSURE SPRINGS	OUTER PRESSURE SPRINGS	SET PRESSURE PSI [BAR]	113% CERTIFIED FULL FLOW SCFM [SM³/S]	113% OVER PRESSURE PSI [BAR]	120% CERTIFIED FULL FLOW SCFM [SM³/S]	120% OVER PRESSURE PSI [BAR]	130% CERTIFIED FULL FLOW SCFM [SM³/S]	130% OVER PRESSURE PSI [BAR]	MASS lb [kg]	HEIGHT A inch [mm]

TABLE 1

Index	Part Number	Description	Material	Qty
8	1860/X191XXZ	PRESSURE PLATE (SEE TABLE 2)	SEE TABLE 2	1
7	1860/0625P	PFA LINED SUPER MAXI BODY MACHINING	CF3M/PFA	1
6	1860/0094	EXTENSION TUBE	316L STST	1
5	1860/0041/9XX	TOP CAP (SEE TABLE 1)	CF8	1
4	10978/1	STAINLESS PLUG	ST ST	1
3	6104-XXXXRI	PRESSURE SPRING (SEE TABLE 1)	INCONEL X750	1
2	5121-001	3/16"BSW.3/16"LG SOCKETHEAD	A2-70	2
1	5120-067	RETAINING RING CLIP	316 STST	1

Assembly BOM

SALES@FORTVALE.COM WWW.FORTVALE.COM

ENGLAND, USA, CHINA
NETHERLANDS, SINGAPORE

© FORT VALE ENGINEERING LTD 2023.

UNLESS OTHERWISE STATED		DO NOT SCALE- IF IN DOUBT ASK	
FIRST ANGLE PROJECTION		MATERIAL: CF3M/PFA	
X.X ±0.5	SURFACE FINISH 3.2um MAX	ISO9001:2015 REGISTERED FIRM: LRQ4007111	SCALE: 3:4
X.XX ±0.25	CORNER RADII 0.8		MASS: 10,03 kg
X.XXX ±0.125	CORNER CHAMFER 1.0 X 45°	CHECKED	DVN: 38739
ANGLES ±0.5°	REMOVE ALL BURRS AND SHARP EDGES		
DESCRIPTION		SHEET 1 OF 1	
PFA LINED 2 1/2" SUPERMAXI HIGH FLOW RV		DRAWN BY: D BAILEY	
TYPE		DATE: 17-Oct-19	
MK3 SUPER MAXI HIGH FLOW		DRG.NO.	
		0U3/XXXX006R	

DRAWING STATUS		PPAP		
REVISION	03	SIG	D BAILEY	22-Nov-23
PRD NUMBER PRD232129 WAS PRD139511				

SECTION A-A

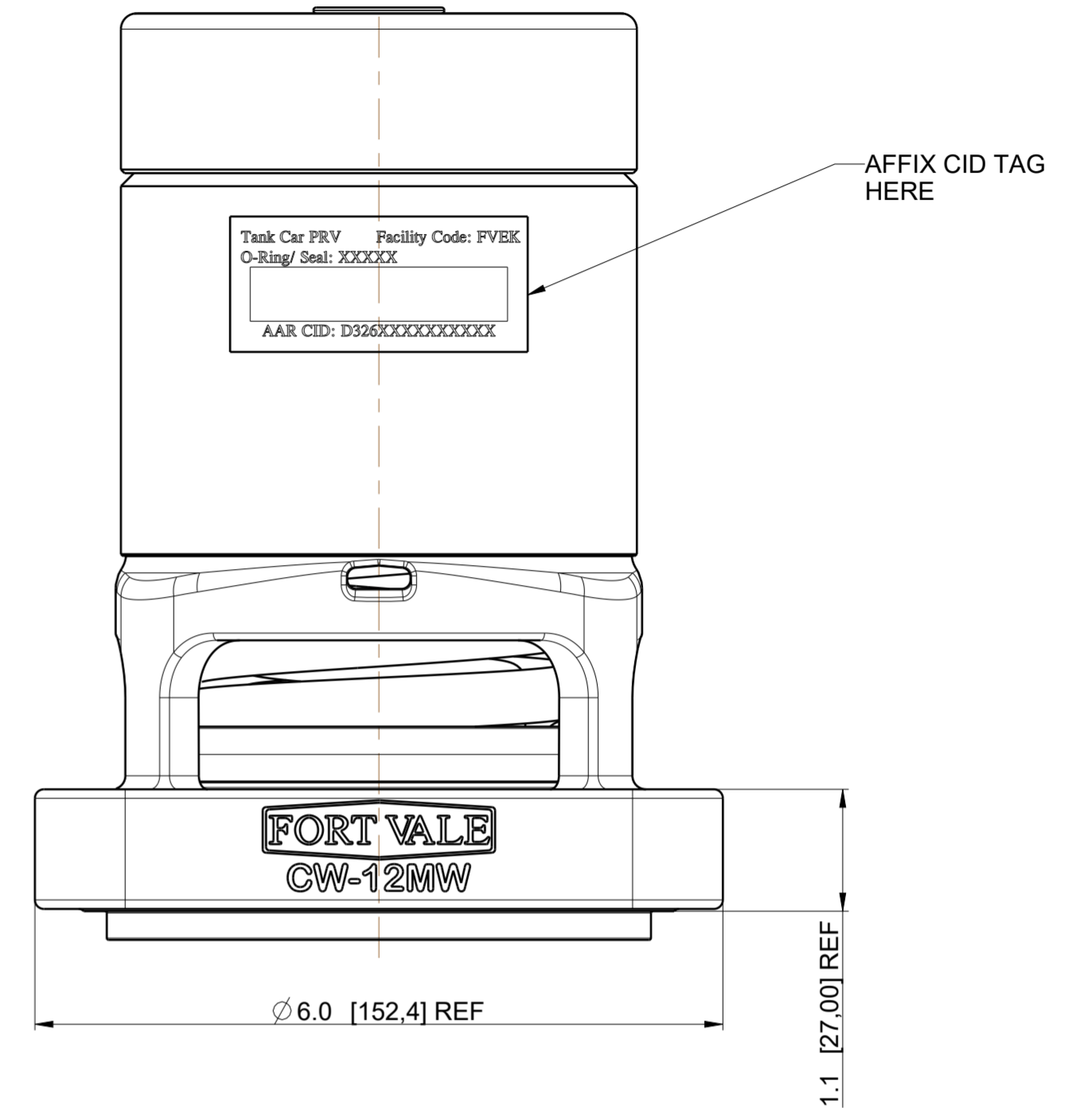
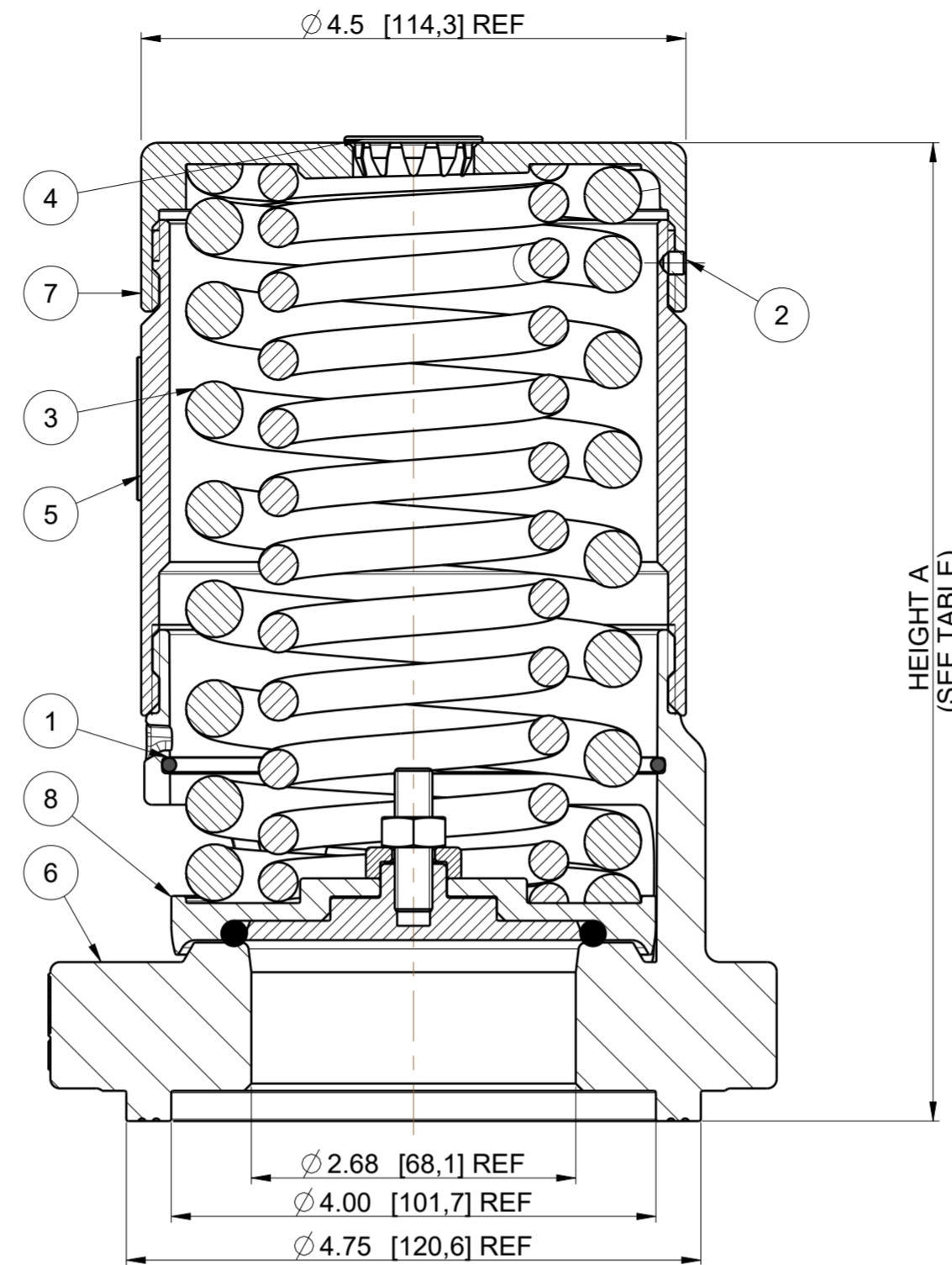
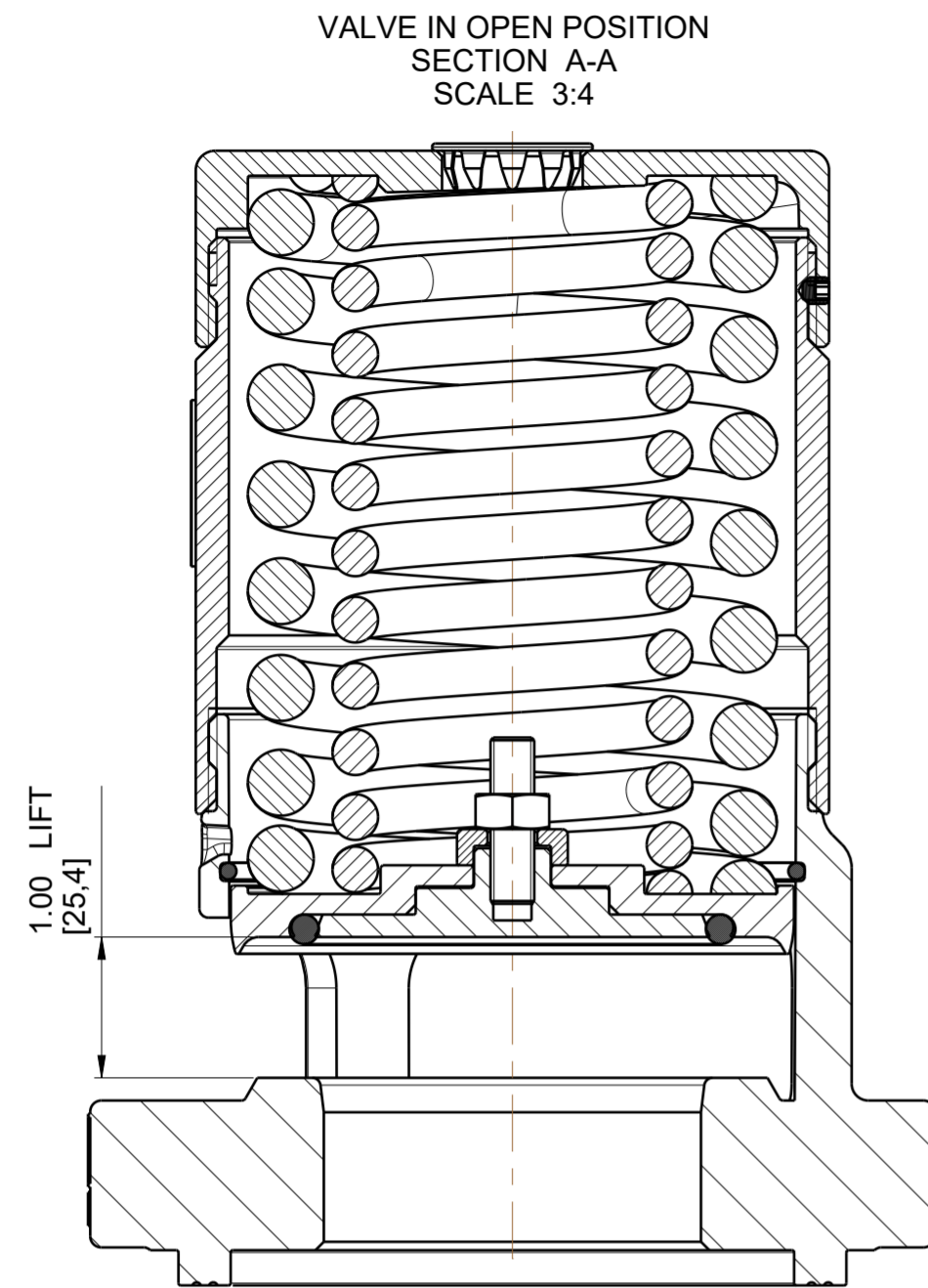

PART NUMBER EXAMPLE :-
HR3/0165006T VALVE DENOTES
65mm RELIEF VALVE SET AT 165 PSIG
PRESSURE SEAL MATERIAL VITON A

AAR APPLICATION NUMBER: PRD232129
NOTE!
SPRINGS MANUFACTURED FROM INCONEL X750

DESIGN CODE: ASME VIII DIV1
DESIGN PRESSURE (MAWP) : 165.1 PSI (11.38 BAR)
SERVICE TEST PRESSURE : 298.8 PSI (20.60 BAR)
MAX DESIGN TEMPERATURE : 302°F (150 °C)
MIN DESIGN TEMPERATURE : -40°F (-40 °C) } FOR METAL PARTS
REFER TO TABLE 2 FOR SEAL TEMPERATURE LIMITATIONS

HR3/WXXX006T	WHITE BUNA N (FOOD GRADE)	1860/W190XXH	-30°C (-22°F)	100° C (212° F)
HR3/TXXX006T	FORTYT PFA OUTER/SILICON CORE	1860/T190XXH	-55° C (-67° F)	150° C (302° F)
HR3/KXXX006T	KALREZ 7275	1860/L190XXH	-20° C (-4° F)	150° C (302° F)
HR3/GXXX006T	VITON GFLT	1860/G190XXH	-40° C (-40° F)	150° C (302° F)
HR3/CXXX006T	CHEMRAZ 505	1860/C190XXH	-30° C (-22° F)	150° C (302° F)
HR3/BXXX006T	VITON B	1860/B190XXH	-40° C (-40° F)	150° C (302° F)
HR3/AXXX006T	AFLAS	1860/T190XXH	-30° C (-22° F)	150° C (302° F)
HR3/7XXX006T	PERFLUOROELASTOMER	1860/K190XXH	-15° C (+5° F)	150° C (302° F)
HR3/1XXX006T	FORTYT FEP OUTER/SILICON CORE	1860/F190XXH	-55° C (-67° F)	150° C (302° F)
HR3/0XXX006T	VITON A	1860/V190XXH	-20° C (-4° F)	150° C (302° F)

TABLE 2

4 HOLES
Ø 0.87 [22.0] THRO'
EQUISPACED AS SHOWN
ON A 6.25 [158.75] PCD.

NOTE!
REPLACE MONTH/YEAR
WITH CURRENT DATE
INFORMATION
E.G. NOVEMBER/2013

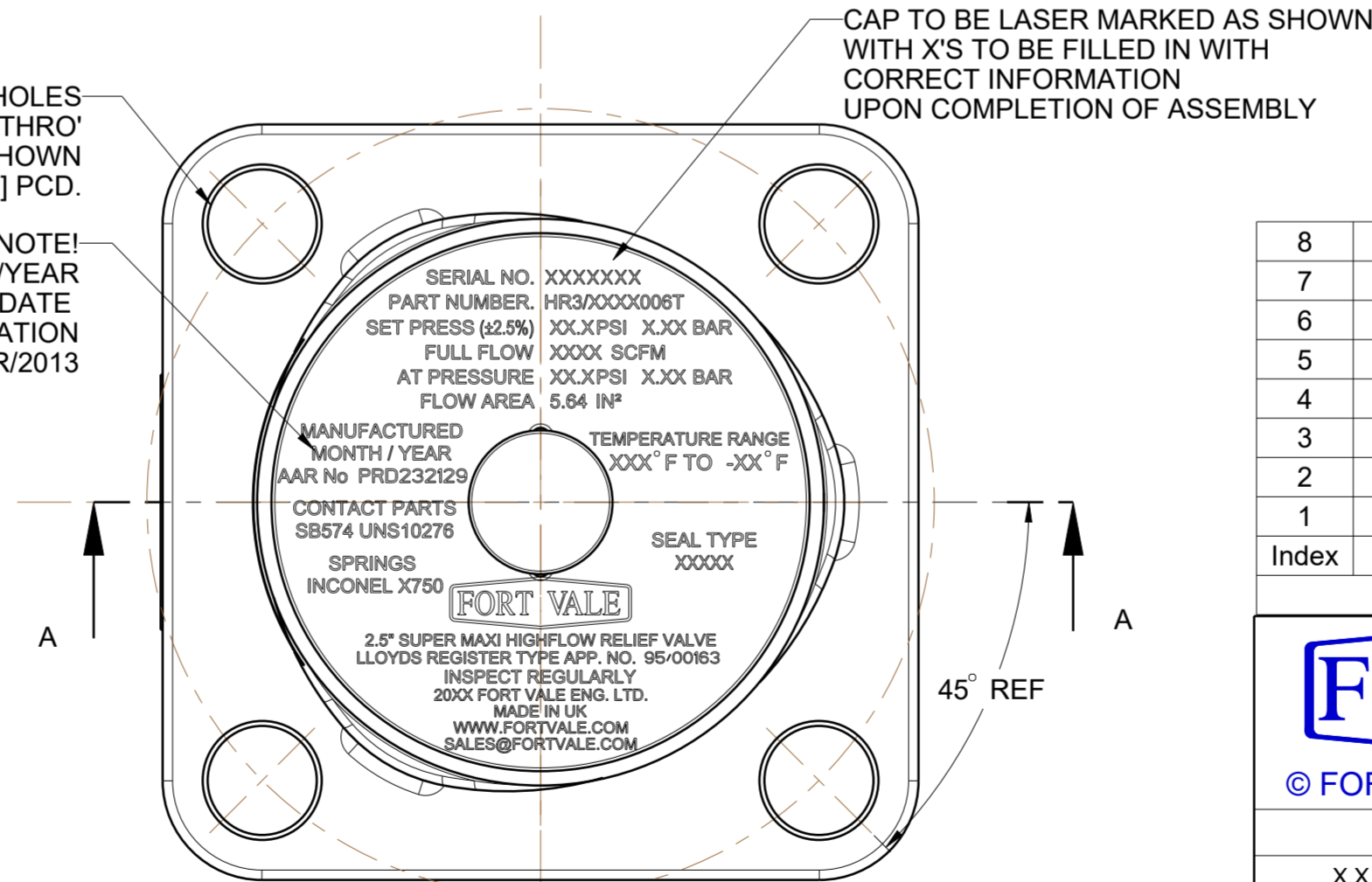

CAP TO BE LASER MARKED AS SHOWN
WITH X'S TO BE FILLED IN WITH
CORRECT INFORMATION
UPON COMPLETION OF ASSEMBLY

PART NUMBER	TOP CAP (ITEM 7)	PRESSURE PLATE (ITEM 8)	INNER SPRING	OUTER SPRING	SET PRESSURE PSI [BAR]	120% CERTIFIED FULL FLOW SCFM [SM ³ /S]	120% OVER PRESSURE PSI [BAR]	130% CERTIFIED FULL FLOW SCFM [SM ³ /S]	130% OVER PRESSURE PSI [BAR]	MASS lb [kg]	HEIGHT A INCH [MM]
HR3/X165006T	1860/HA41/49	1860/X19048H	6104-1264RI	SPRING PAIR	165.0 [11,38]	22286 [10,52]	198.0 [13,66]	24000 [11,33]	214.5 [14,79]	24.5 [11,1]	8.08 [205,2]

TABLE 1

Index	Part Number	Description	Material	Qty
8	1860/X190XXX	COMPOSITE PRESSURE PLATE (SEE TABLES 1&2)	VARIOUS	1
7	1860/HA41/XX	TOP CAP (SEE TABLE 1)	CW-12MW	1
6	1860/H626	VALVE BODY MACHINED	CW-12MW	1
5	1860/0095H	EXTENSION TUBE	N10276	1
4	10978/1	STAINLESS PLUG	304L STST	1
3	6104-XXXXRI	PRESSURE SPRING (SEE TABLE 1)	INCONEL X750	1
2	5121-001	3/16"BSW.3/16"LG SOCKETHEAD	A2-70	1
1	5120-067H	RETAINING RING CLIP	N10276	1

Assembly BOM

SALES@FORTVALE.COM WWW.FORTVALE.COM

ENGLAND, USA, CHINA
NETHERLANDS, SINGAPORE

© FORT VALE ENGINEERING LTD 2023.

DO NOT SCALE- IF IN DOUBT ASK

UNLESS OTHERWISE STATED

FIRST ANGLE PROJECTION

MATERIAL: UNS 10276

SCALE: 3:4 MASS: (SEE TABLE 1)

CHECKED: DVN: 38739

ISO9001:2015 REGISTERED FIRM: LRQ4007111

REMOVE ALL BURRS AND SHARP EDGES

DESCRIPTION: 2.5" SUPERMAXI HIGHFLOW R/V

TYPE: MK3 SUPER MAXI HIGH FLOW

SHEET 1 OF 1

DRAWN BY: P BOULT DATE: 14-May-15

DRG.NO. HR3/XXXX006T