



WARNING: Installation, usage and maintenance of this product must be in compliance with all RegO® instructions as well

as requirements and provisions of NFPA #54, NFPA #58, DOT, ANSI, all applicable federal, state, provincial and local standards, codes, regulations and laws.

Repairs of the seals should be done with hands clothing and tools free of oil, grease and foreign matter to prevent contamination of component parts.

Inspection and maintenance on a periodic basis is essential. Installation, disassembly, repair and maintenance must be performed only by qualified personnel.

Be sure all instructions are read and understood before installation, operation and maintenance. These instructions must be passed along to the end user of the product.

RegO Rail Tank Car equipment is AAR approved. If repaired, the continued validity of the AAR approval is contingent upon proper inspection to determine what needs to be repaired; proper repair using RegO OEM parts and procedures, proper testing for leakage and performance following repairs and installation.

ECI EXPRESSLY DISCLAIMS ANY AND ALL LIABILITY – UNDER ANY THEORY, WHETHER CONTRACT, WARRANTY, TORT OR OTHERWISE – RELATING IN ANY MANNER TO ANY RAIL TANK CAR EQUIPMENT REPAIRED USING ANY PRODUCTS NOT MANUFACTURED BY ECI.

USE OF ANY PRODUCTS NOT MANUFACTURED BY ECI TO REPAIR ANY RAIL TANK CAR EQUIPMENT WILL INVALIDATE ANY AND ALL WARRANTIES OF THE RAIL TANK CAR EQUIPMENT, WHETHER EXPRESS OR IMPLIED.

CAUTION: Contact or inhalation of LP-Gas, ammonia and their vapors can cause serious injury or death! NH₃ and LP-Gas must be released outdoors in air currents that will insure dispersion to prevent exposure to people and livestock. LP-Gas must be kept far enough from any open flame or other source of ignition to prevent fire or explosion! LP-Gas is heavier than air and may not disperse or evaporate rapidly if released in still air.

Disassembly and Rebuild Procedure

CAUTION: READ THROUGH ALL OF THESE INSTRUCTIONS, INCLUDING THE NOTICE AND WARNINGS ON THE BACK OF THIS SHEET, BEFORE BEGINNING ANY DISASSEMBLY OR REPAIR.

NOTE: Repairs must be performed in a clean area. Hands, clothing, tools and work area must be completely free of oil, grease and foreign matter to prevent contamination of component parts and valves. Take care to prevent damage to the epoxy coating on the springs.

Disassembly and Repair Procedure

A. Angle Valve Disassembly - See Figures 1, 2 & 3

1. **EVACUATE ALL GAS FROM THE SYSTEM BEFORE ANY DISASSEMBLY OR REPAIR.** Turn handwheel counterclockwise as far as it will go to release any gas remaining in the container.

CAUTION: Do not apply force after valve is fully open.

2. Using a 13/16" wrench, remove the four cap screws from the bonnet by turning counterclockwise. Remove the bonnet assembly from the valve body by carefully pulling upward using the handwheel. Carefully place the bonnet assembly on its side to prevent any damage to the drive stem. See Figure 2.

3. Remove the body gasket and discard.

Seat Disc Replacement:

4. Clamp the square section of the bonnet in a vise.
5. Using 1-1/8" wrench on the stem holder (left hand threads) and a 1-5/16" wrench on seat disc retainer (left hand threads) turn clockwise (left hand threads) (as shown in Figure 3) to loosen the stem holder from the seat disc retainer.
6. Remove and retain the two stem retainers (crescent shaped) once the stem holder and seat disc retainer are separated.
7. Carefully support the main stem while using a punch to remove the 3/32" stainless steel spring pin from the drive stem (See Figure 3). Discard the pin after removal.
8. Use a 3/8" wrench on the hex portion of the drive stem, turn clockwise (left hand threads) to separate the drive stem from the main stem. Retain the drive stem for reassembly. Clean the old Loctite from all threads.

NOTE: It is helpful to hold the handwheel to aid in the removal of the drive stem.

EA7814-50 Rebuild Assembly for EA7814 Angle Valve and EA3214 Internal Valve

Tank Car Valve
Figure 1

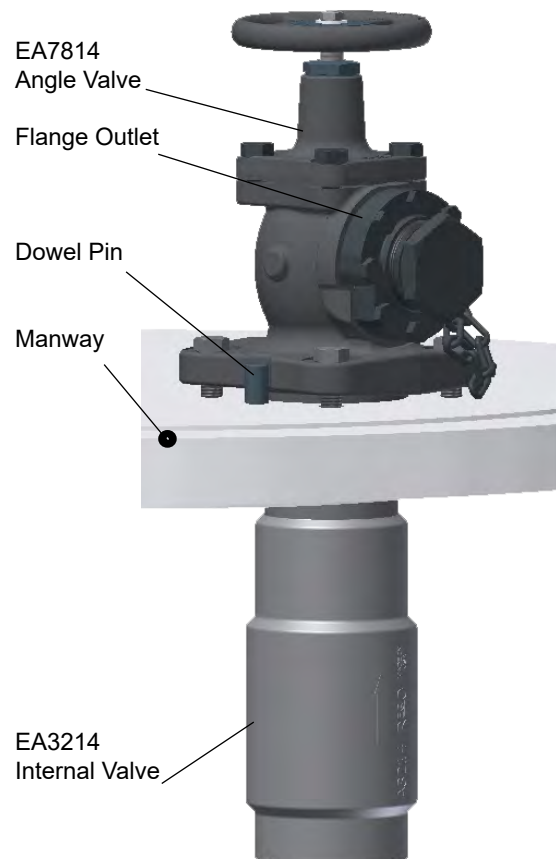

9. Remove and discard the old thrust washer and old o-ring.
10. While holding the wrench flat section of the seat disc retainer with a 1-5/16" wrench, use another wrench to remove the seat disc retainer nut.
11. Remove and discard the seat disc. Install a new one by pressing it into the recess of the seat disc retainer as shown in Figure 3.
12. Apply Loctite 271® thread locking compound to the first three threads of the seat disc retainer.

CAUTION: Do not allow Loctite to contact the seat disc.

13. Thread on the seat disc retaining nut and tighten with a wrench to 240-270 in-lbs (20-22.5 ft-lbs) torque. Stake the nut in two places at the retainer threads (See Figure 3) to prevent loosening.

Packing Replacement:

14. Remove the handwheel locknut by turning counterclockwise with a small wrench to allow removal of the washer, information disc and handwheel. Retain all parts.
15. Using a 1-3/8" wrench with a handle of sufficient length to develop a minimum of 1000 in-lbs torque, turn the seal housing counterclockwise and carefully remove from the bonnet and stem.
16. Remove and discard (2) pressure seal rings, jam ring and wiper o-ring from seal housing and set seal housing aside.

CAUTION: Do not mar the finish of the stem.



- Using a suitable wrench on the square section of the stem, unscrew the stem down and out through the bottom of the bonnet by turning clockwise (as viewed from the top).

CAUTION: Stem inspection required.

- Inspect the stem closely for definite signs of wear, nicks or scratches, in the Stem Sealing Area, see figure 2. If any mechanical cleaning is needed, use emery cloth or paper (500-1000 grit) and polish stem sealing area using a circular motion.

CAUTION: Raised or sharp edges on the stem can damage and expand the packing seals when pressing onto the stem.

- Continue to inspect the handwheel resting location where the stem changes from square to round, see figure 2 *Handwheel Resting Location*. Remove any raised edges or burrs using a fine file and emery cloth that are higher than the stem diameter. Using an old seal, press seal on and off this area to determine if any resistance is felt. Resistance may require additional clean up. If stem is found to be in good condition, continue section B-1 of the rebuild instructions.

NOTE: If any permanent damage is found discard the stem, drive stem, driver weldment and seal housing. Use TA7814-51 Stem Kit and follow the alternate steps outlined in section B-2 Titled Angle Valve Reassembly Instructions with the TA7814-51 Stem Kit.

- Remove and discard seal housing gasket, washer, and spring from bonnet.

NOTE: Inspect stem^A threads and mating threads in bonnet^{}. If any threads show definite wear, discard part and install a new one.**

- Remove adjusting screw and hex nut from the driver weldment and retain.
- Remove the driver weldment and inspect the threads for wear, chips, etc. Replace as needed.
- Remove and retain eight cap screws securing the flange outlet using a 9/16" wrench. Remove and discard flange gasket, see

EA7814 Angle Valve

Figure 2

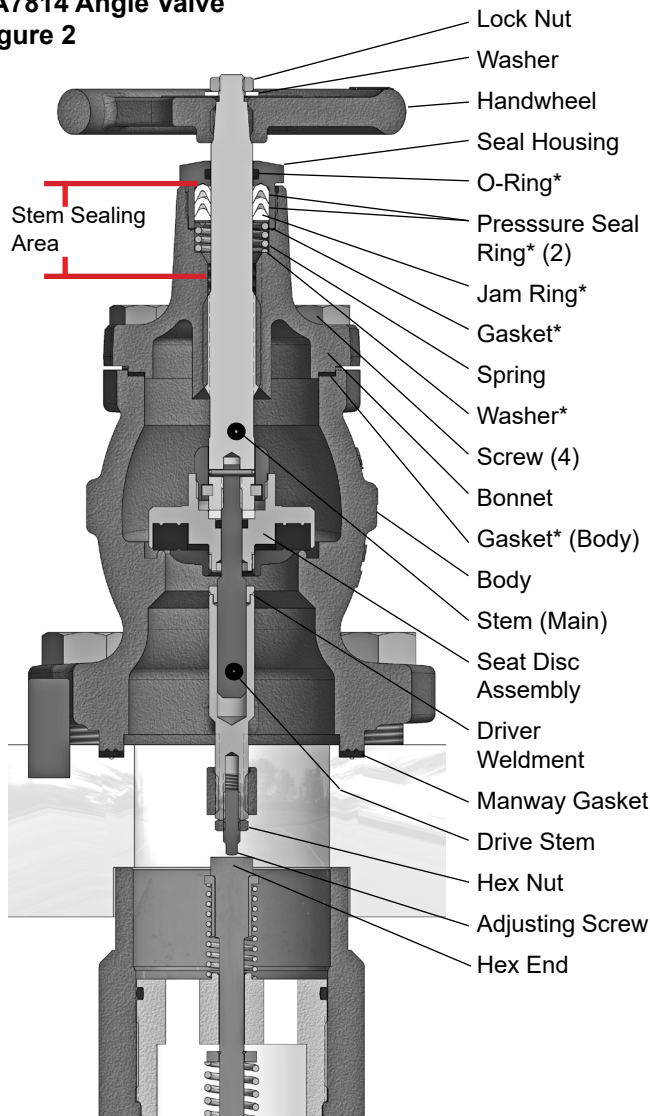

figure 1.

B-1 Angle Valve Reassembly - See Figures 1,2 & 3

- Apply non-detergent grease liberally to the threads of the main stem.
- Screw the main stem clockwise (as viewed from seat disc) into the bottom of the bonnet with great care to avoid damaging the stem finish.
- Install the new seal housing gasket, new spring, new washer and jam ring over the main stem and into the bonnet.
- Install the new wiper o-ring in the groove of the seal housing.
- Apply a thin film of non-detergent grease to the pressure seal rings and carefully insert one at a time into the full depth of the seal housing.
- Apply 1/8" stripe of Loctite 271® thread locking compound across the threads in three places equally spaced around the seal housing.
- Place the seal housing carefully over the main stem to avoid damaging the edges of the seal rings and thread into the bonnet clockwise. Tighten to 800±25 in-lbs (67±2 ft-lbs) torque, using a 1-3/8" wrench with a handle of appropriate length.
- Place the handwheel and information disc on the stem, secure with the washer and locknut and tighten firmly with a 9/16" wrench.

Stem and Seat Disc Retainer Reassembly

- Apply fluorinated grease to the new o-ring, thrust washer and old drive stem.
- Install the stem holder on the main stem.
- Insert the drive stem through the seat disc retainer and carefully install the o-ring and thrust washer over the drive stem and slide them down into the seat disc retainer cavity.

CAUTION: Do not cut the o-ring or thrust washer on the threads of the drive stem. The threads can be "masked" to prevent damage using tape or equivalent.

- Remove any grease from the drive stem threads.
- Apply Loctite 271® thread locking compound to the drive stem threads and tighten counterclockwise into the main stem (left hand threads). Align the cross drilled holes in the main stem and drive stem. A small rotation might be necessary to align the holes once the new drive stem is tightened.
- Install the new 3/32" spring pin flush with the edge of the main stem.
- Install the two (crescent shaped) stem retainers onto the main stem.
- Apply Loctite 271® thread locking compound to the stem holder external threads and tighten into the seat disc retainer. Using 1-1/8" wrench on the stem holder and 1-5/16" wrench on the seat disc retainer, torque the connection to insure metal to metal contact

EA7814 Seat Disc Assembly

Figure 3

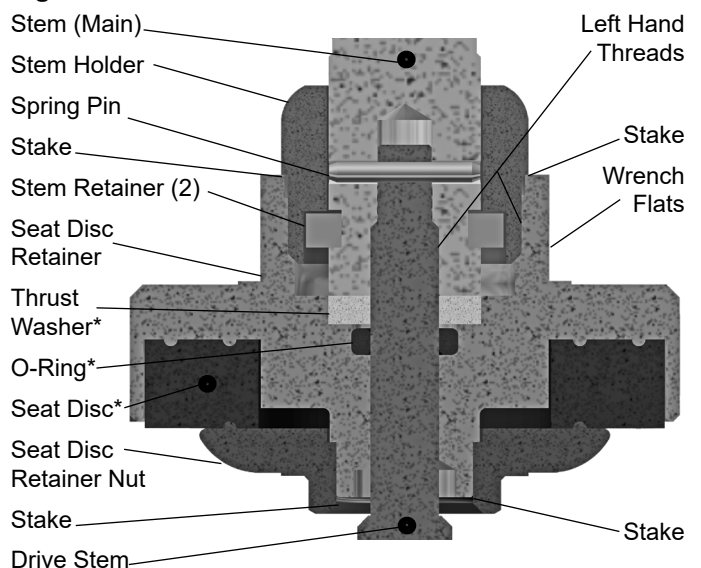

between the two. Stake as shown in Figure 3 (two places).

17. Apply non-detergent grease to the driver weldment threads, then tighten (left hand threads) clockwise until seated against the "web" in the valve body. Replace the adjusting screw and hex nut on the driver weldment (See Figure 6) for installing new ones. Verify the main stem and seat assembly is back seated in the bonnet assembly.
 18. Apply non-detergent grease to each side of the new gasket and install the gasket in the body (between the bonnet & body).
- CAUTION: Main stem must be in the full open (valve back seated) position to prevent seat disc from being forced against the body seat when the bonnet is assembled to the valve body.**
19. Place the bonnet assembly over the body and align the holes for the cap screws. Using handwheel to verify the drive stem and the driver weldment nest properly together. Slight adjustment is allowed to assemble the bonnet to the body.
 20. Using a 13/16" wrench, partially tighten one cap screw, then move diagonally across the bonnet to tighten the second cap screw. Continue until all four cap screws are tightened to 540±25 in-lbs (45±2 ft-lbs) torque. See Figure 4A.
 21. Turn handwheel clockwise to the closed position.
 22. Apply non-detergent grease to each side of the new outlet flange gasket and install. Torque each cap screw 300±25 in-lbs (25±2 ft-lbs) minimum using a crisscross tightening sequence. See Figure 4B.

B-2 Angle Valve Reassembly With TA7814-51 Stem Kit - See Figures 1,2 & 3

1. Discard the stem, drive stem, driver weldment, and seal housing.
2. Apply non-detergent grease liberally to the threads of the new main stem.
3. Screw the new main stem clockwise (as viewed from seat disc) into the bottom of the bonnet with great care to avoid damaging the stem finish.
4. Install the new seal housing gasket, new spring, new seal housing washer and jam ring over the main stem and into the bonnet.
5. Install the new wiper o-ring in the groove of the new seal housing.
6. Apply a thin film of non-detergent grease to the pressure seal rings and carefully insert one at a time into the full depth of the new seal housing.
7. Apply 1/8" stripe of Loctite 271® thread locking compound across the threads in three places equally spaced around the new seal housing.
8. Place the new seal housing carefully over the main stem to avoid damaging the edges of the seal rings and thread into the bonnet clockwise. Tighten to 800±25 in-lbs (67±2 ft-lbs) torque, using a 1-3/8" wrench with a handle of appropriate length.
9. Place the handwheel and information disc on the new stem, secure with the washer and locknut and tighten firmly with a 9/16" wrench.

Stem and Seat Disc Retainer Reassembly

10. Apply fluorinated grease to the new o-ring, thrust washer and new drive stem.
11. Install the stem holder on the main stem.
12. Insert the drive stem through the seat disc retainer and carefully install the o-ring and thrust washer over the drive stem and slide them down into the seat disc retainer cavity.

CAUTION: Do not cut the o-ring or thrust washer on the threads of the new drive stem. The threads can be "masked" to prevent damage using tape or equivalent.

13. Remove any grease from the drive stem threads.

14. Apply Loctite 271® thread locking compound to the new drive stem threads and tighten counterclockwise into the main stem (left hand threads). Align the cross drilled holes in the new main stem and new drive stem. An additional counterclockwise rotation (approximately 60 in-lbs (5 ft-lbs)) might be necessary to align the holes once new drive stem is tightened.
15. Install the new 3/32" spring pin flush with the edge of the new

EA7814 Angle Valve Flange Tightening Sequence Figure 4B

1 - 5 - 2 - 6 - 3 - 7 - 4 - 8

Apply a minimum of 300±25 in-lbs torque using a tightening sequence of alternating bolts in a crisscross pattern.

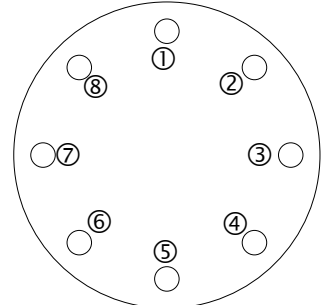

EA3214 Internal Valve Figure 5

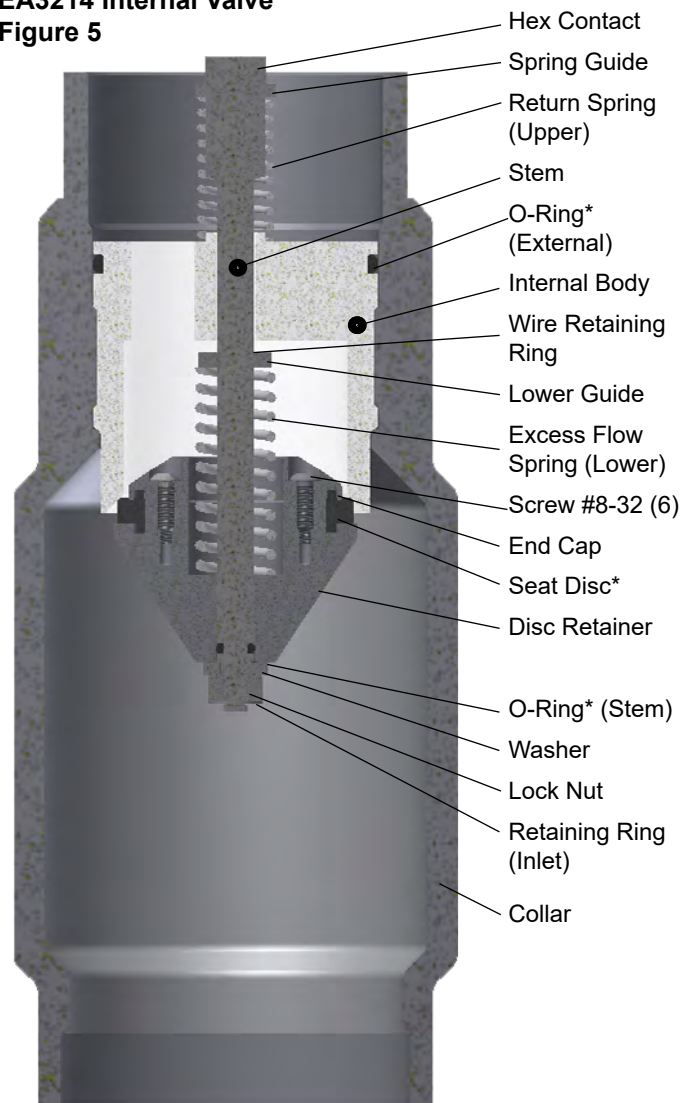

* Items supplied in the EA7814-50 rebuild kit.
 ** Must be ordered separately from RegO®.

EA7814 Angle Valve Bonnet Tightening Sequence Figure 4A

1 - 3 - 2 - 4

Apply a minimum of 540±25 in-lbs torque using a tightening sequence of alternating bolts in a crisscross pattern.

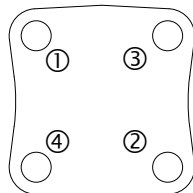

main stem.

16. Apply non-detergent grease to the two (crescent shaped) stem retainers. Install these on the new main stem.
17. Apply Loctite 271® thread locking compound to the stem holder external threads and tighten into the seat disc retainer. Using 1-1/8" wrench on the stem holder and 1-5/16" wrench on the seat disc retainer, torque the connection to insure metal to metal contact between the two. Stake as shown in Figure 3 (two places).
18. Apply non-detergent grease to the new driver weldment threads, then tighten (left hand threads) clockwise until seated against the "web" in the valve body. Replace the adjusting screw and hex nut on the new driver weldment (See Figure 6) for installing new ones. Verify the new main stem and seat assembly is back seated in the bonnet assembly.
19. Apply non-detergent grease to each side of the new gasket and install the gasket in the body (between the bonnet & body).

CAUTION: Main stem must be in the full open (valve back seated) position to prevent seat disc from being forced against the body seat when the bonnet is assembled to the valve body.

20. Place the bonnet assembly over the body and align the holes for the cap screws. Using handwheel to verify the new drive stem and the new driver weldment nest properly together. Slight adjustment is allowed to assemble the bonnet to the body.
21. Using a 13/16" wrench, partially tighten one cap screw, then move diagonally across the bonnet to tighten the second cap screw. Continue until all four cap screws are tightened to 540±25 in-lbs (45±2 ft-lbs) torque. See Figure 4A.
22. Turn handwheel clockwise to the closed position.
23. Apply non-detergent grease to each side of the new outlet flange gasket and install. Torque each cap screw 300±25 in-lbs (25±2 ft-lbs) minimum using a crisscross tightening sequence. See Figure 4B.

C. Removal of EA3214 Internal Valve - See Figures 2 & 5

1. If applicable, remove the EA7814 Angle Valve from the manway cover and set aside in a manner to avoid damage to adjusting screw.
2. Use a spanner wrench or equivalent to remove the internal valve from the collar.
3. Remove and discard the external o-ring.
4. Remove and retain the retaining ring from the inlet side of the main stem.
5. Using a 1/2" wrench on the hex nut at the end of the stem and a 9/16" or a 11/16" socket on the hex contact (may have either size), remove the hex nut from the stem by loosening counterclockwise.

CAUTION: Seat disc retainer is under a spring load and must be retained and slowly released to prevent possible injury or damage to parts.

6. Remove and retain the washer.

Seat Disc Replacement:

7. Depress the hex contact of the stem while holding seat retainer in closed position to enable the removal of the stem o-ring. Remove and discard the o-ring.
8. Slide the seat disc retainer assembly from the stem.
9. Remove and retain the six #8-32 screws and the end cap from the assembly.
10. Remove and discard the old seat disc.
11. Install the new seat disc and replace end cap using the six #8-32 screws. Apply Loctite 242® thread locking compound to threads of each screw and securely tighten to ensure metal to metal contact between the end cap and the poppet body.

NOTE: The stem does not need to be removed unless significant wear is visible or if the valve binds during closing and opening.

12. Inspect the stem for damage. If it is necessary to completely remove the stem from the body go to step 13. If the stem does not need to be removed, skip step 13.

13. Remove the Stem from the Body:

- a. Remove and retain the lower spring (excess flow).
- b. Remove and retain the lower guide.
- c. Depress the hex contact on stem and remove the wire retaining ring and discard.

CAUTION: Do not damage the stem by scratching, nicking or gouging.

- d. Remove and retain the stem and the upper spring

(return) for reassembly.

NOTE: If the stem is scratched or scored, a new one must be installed.**

- e. Install the spring guide and upper spring (return) on to the stem, then insert the stem into the internal valve body.
 - f. Depress the hex contact of the stem and insert the new wire retaining ring.
 - g. Install the lower guide.
 - h. Install the lower spring (excess flow).
14. Install the seat disc retainer assembly carefully over the stem.
 15. Depress the hex contact of the stem while holding seat retainer in closed position to enable the installation of the stem o-ring. Lubricate the new o-ring with fluorinated grease and carefully install on the stem. Careful not to cut the o-ring on any edges, corners or threads of the stem.

NOTE: Masking edges, threads and corners is an acceptable method to prevent o-ring damage.

16. Apply Loctite 271® thread locking compound to male threads on the end of the stem.

CAUTION: Do not get Loctite on the o-ring.

17. Install the washer and hex nut. Torque to 25-35 in-lbs (2-3 ft-lbs).
18. Install the old retaining ring (inlet).
19. Lubricate the external o-ring with fluorinated grease and install into the o-ring groove of internal valve.
20. Apply anti-seize to the male threads of the internal valve body. Thread the internal valve assembly into the collar and hand tighten to full engagement. Once the assembly bottoms out against the internal stop in the collar, no further torque is required or recommended.

D. Reassembly to the Manway - See Figures 1 & 6

Internal Valve Measurement Check and Installation

1. Thread the Internal Valve body and poppet assembly into the collar and hand tighten until it bottoms out, indicating full engagement.
2. Measure from the top of the manway cover to the top face of the hex contact, see distance "A". "A" should measure between 1.665" min and 1.725" max if the Internal Valve is properly installed.
3. If "A" distance is not correct, recheck that the body and poppet assembly was installed correctly in the collar and the Internal Valve is positioned correctly.

NOTE: There is no adjustment allowed to the Internal Excess Flow Valve.

Angle Valve Measurement Check and Installation

NOTE: Verify that the Angle Valve is fully closed.

4. Measure from the bottom of the Tank Car Valve's grooved surface

TA7814 Tank Car Valve Measurement Check

Figure 6

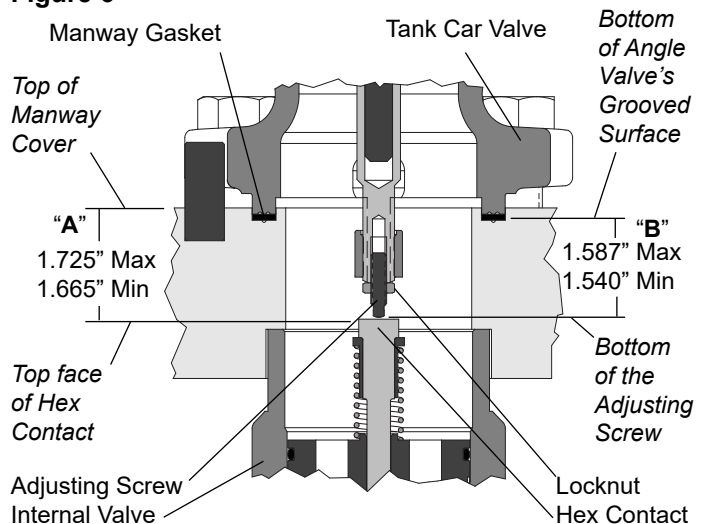

Proper clearance must be held between the globe valve adjusting screw and the internal valve hex contact.

EA3214 Internal Valve - How the Valve Works - Figure 7

Tank Car & Internal Valve in Fully Closed Position

1. Fully Closed

In the fully closed position, the valve is held closed without leakage by tank pressure and the Internal Valve's closing spring.

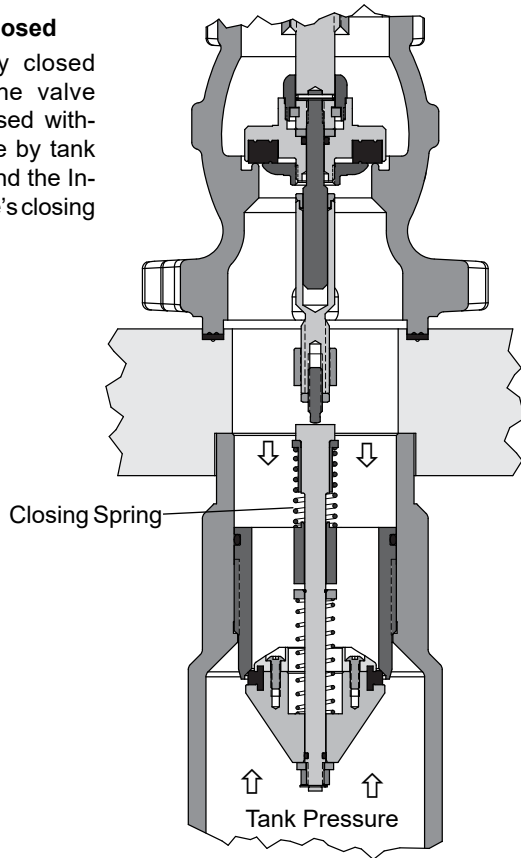

Tank Car & Internal Valve in Mid-Point Position

2. Rapid Bleed

Actuation of the operating handwheel alone does not open the valve, it only allows pressure to equalize between the inlet and outlet of the valve by rapid bleeding of the product downstream. This equalized pressure then allows the valve to open via the excess flow spring.

The valve is opened by moving the handwheel to mid-point. This moves the actuator to the equalizing position which allows product to bleed downstream.

The equalizing position allows more product to bleed downstream than if the handwheel was fully open.

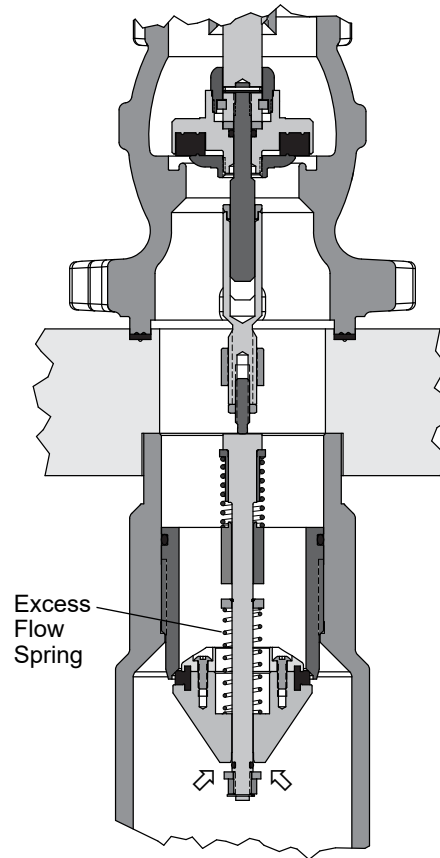

Tank Car & Internal Valve in Fully Open Position

3. Fully Open

In a few seconds, the tank and downstream pressure will be equalized, allowing the excess flow spring to push the poppet to the open position. The handwheel should then be moved to the fully opened position. If the handwheel is quickly moved to the fully opened position, the equalization passage allows a small amount of bleed downstream, but much less than during the rapid bleed. This results in a longer pressure equalizing time before the valve can open.

NOTE: The poppet will not open until outlet pressure approximates tank pressure!

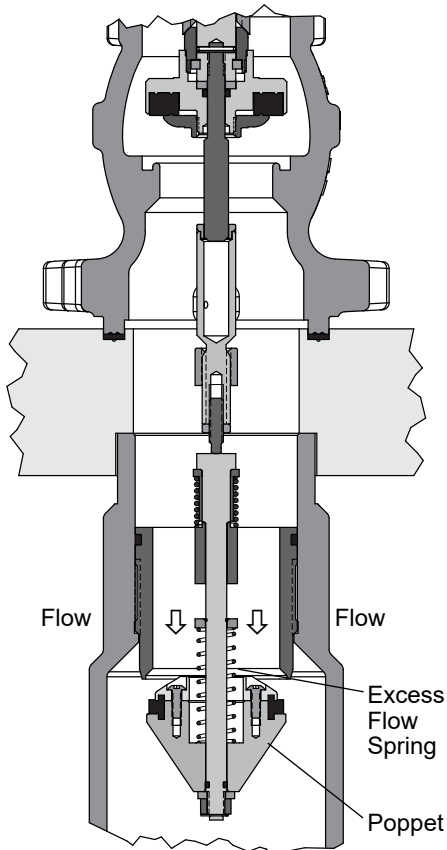

Tank Car in Fully Open & Internal Valve in Partial Closed Position

4. Limit Bleed

Once the poppet is open, flow greater than the excess flow spring rating, or a sufficient surge in force of the flow, forces the poppet closed against the excess flow spring. The equalization passage in this position is open and allows a small amount of bleed downstream, but much less than during rapid bleed. When the operating handwheel is moved to the closed position, the valve closes and a tight, leakproof seal is re-established as seen in Step 1.

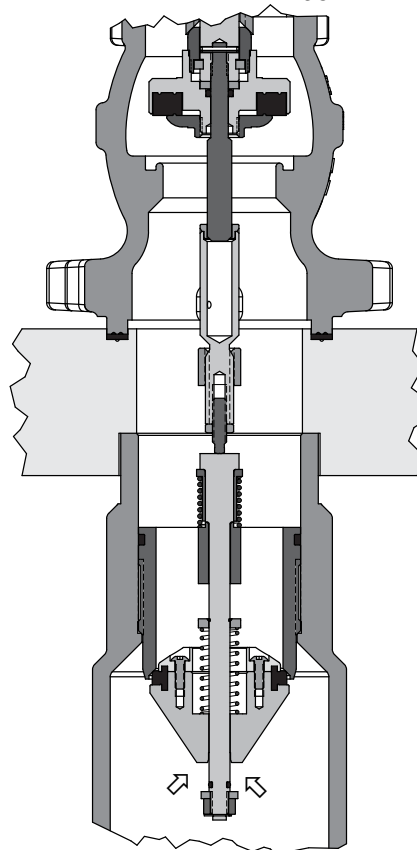

to the bottom of the adjusting screw, see distance "B". "B" should measure between 1.540" min and 1.587" max, as preset by factory. If distance "B" does not fall within the specified range, loosen the locknut, then adjusting screw until "B" distance is achieved. Hold adjusting screw and tighten locknut. Verify that the distance is unchanged after tightening the locknut. This will provide the necessary clearance needed for proper operation of the valve.

- Apply fluorinated grease to the bottom of the adjusting screw of the Angle Valve before installing onto the manway cover.
- Install manway gasket (not provided) then, install the Angle Valve on the manway cover carefully aligning with dowel pin in manway and attach using 4-7/8" cap screws (not provided). Tighten to ensure a leak tight joint.
- Pressurize the system to systematically check all valves, joints, connections and seals to verify leak tight connections are intact using a high quality leak detection solution.

Filling and Withdrawal of Product - See Figure 8

Please read and follow all instructions regarding filling and withdrawal of product from the container utilizing the A7814 or EA7814 Angle Valve and A3214-L2, A3214-V2, EA3214-L2 or EA3214-V2 Internal Excess Flow Valve.

If the filling or withdrawal instructions are not explicitly followed then the Internal Valve's excess flow feature will activate. Improper usage resulting in repeated closing of the Internal Valve during filling, evacuating or disconnecting will cause significant damage to the valve's seat.

The filling and withdrawal instructions are show in Figure 8.

To fully understand how the excess flow feature works please see explanation and Figure 7. This explains how the valve is designed to operate in the four possible conditions.

TA7814 Filling and Withdrawal of Product

Figure 8

This decal can be purchased seperately under part number TA7814-72.

DANGER READ FIRST **WARNING**

EXPOSURE TO ANHYDROUS AMMONIA IS CORROSIVE TO HUMAN TISSUE. IT CAN BE LIFE THREATENING AND MAY EVEN CAUSE DEATH. IT IS CLASSIFIED AS AN INHALATION HAZARD. USE PROPER SAFETY EQUIPMENT TO PROTECT AGAINST CONTACT WITH ANHYDROUS AMMONIA.

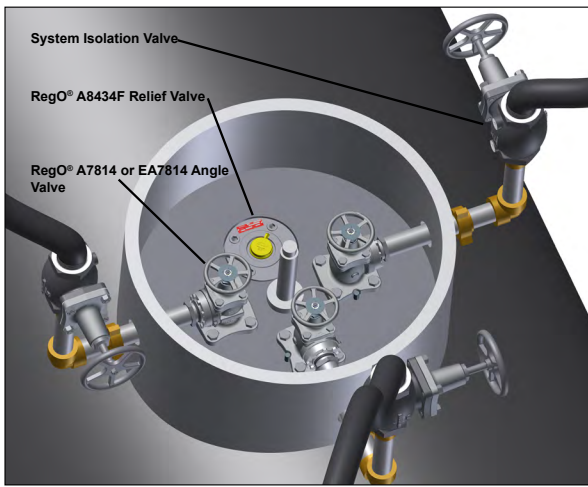

RegO® Valve Operation

1. Connect the appropriate piping to the outlet of all RegO® A7814 Angle Valves.
*****THE SYSTEM ISOLATION VALVES MUST BE CLOSED*****
2. Open each Angle Valve two (2) full turns counterclockwise.
3. Allow 20 seconds for the pressure to equalize.
4. Once the pressure equalizes, open the RegO® Angle Valves by turning counterclockwise completely to back seat the valves.
5. Open the System Isolation Valves.
6. Begin loading/unloading product from the railcar.

NOTICE

LP-Gas is extremely flammable and explosive. Failure to install parts exactly as described in the instructions could result in a product that will not perform satisfactorily. Even if parts are correctly installed, the product might fail to perform satisfactorily, if other parts are worn, corroded or dirty. Improper repair can cause leaks and malfunction, which could result in bodily injury and property damage. Any such use or installation of parts must ONLY be done by experienced and trained personnel using accepted governmental and industrial safety procedures.

Most RegO® products are listed with Underwriters Laboratories as manufactured. If repaired, the continued validity of the UL listing is contingent upon proper inspection to determine what needs repairing, proper repair using RegO® parts and procedures, and proper testing for leakage and performance following repairs and installation.

RegO® assumes no responsibility or liability for performance of products repaired in the field. It must be clearly understood that the person or organization repairing the product assumes total responsibility for performance of the product.

LIMITED 10 YEAR WARRANTY

RegO® warrants to the original purchasers the products and repair kits manufactured by it to be free from defects in materials and workmanship under normal use and service for a period of 10 years from the date of manufacture. If within thirty days after buyer's discovery of what buyer believes is a defect, buyer notifies in writing and ships (at buyer's expense) the product to RegO® at 100 RegO Drive, Elon, N.C. 27244, RegO®, at its option, and within forty-five days of receipt, will repair, replace F.O.B. point of manufacture, or refund the purchase price of that part or product found by RegO® to be defective. Failure of buyer to give such written notice and ship the product within thirty days shall be deemed an absolute and unconditional waiver of any and all claims of buyer arising out of such defect.

This warranty does not extend to any product or part that is not installed and used continuously after installation in accordance with RegO's printed instructions, all applicable state and local regulations, and all applicable national standards, such as those promulgated by NFPA, DOT and ANSI. This warranty does not extend to any product or part that has been damaged by accident, misuse, abuse, failure to maintain, or neglect, nor does it extend to any product or part which has been modified, altered, disassembled, or repaired in the field. This warranty does not cover any cosmetic issues, such as scratches, dents, marring, fading of colors or discoloration.

EXCEPT AS EXPRESSLY SET FORTH ABOVE, AND SUBJECT TO THE LIMITATION OF LIABILITY BELOW, REGO® MAKES NO OTHER WARRANTY, AND EXPRESSLY DISCLAIMS, ANY EXPRESS OR IMPLIED WARRANTIES, INCLUDING, BUT NOT LIMITED TO, THE IMPLIED WARRANTIES OF MERCHANTABILITY AND FITNESS FOR A PARTICULAR PURPOSE, WITH RESPECT TO ITS PRODUCTS AND PARTS, WHETHER USED ALONE OR IN COMBINATION WITH OTHERS. REGO® DISCLAIMS ALL WARRANTIES NOT STATED HEREIN.

This Limited Warranty is given by Engineered Controls International LLC, of 100 RegO Drive Elon, NC 27244 USA, (336) 449-7707.

LIMITATION OF LIABILITY

RegO® total liability for any and all losses and damages arising out of any cause whatsoever shall in no event exceed the purchase price of the products or parts in respect of which such cause arises, whether such causes be based on theories of contract, negligence, strict liability, tort or otherwise.

RegO® shall not be liable for incidental, consequential or punitive damages or other losses. RegO® shall not be liable for, and buyer assumes any liability for all personal injury and property damage connected with the handling, transportation, possession, further manufacture, other use or resale of products, whether used alone or in combination

with any other products or materials.

From time to time buyers might call to ask RegO® for technical advice base upon limited facts disclosed to RegO®. If RegO® furnishes technical advice to buyer, whether or not a buyer's request, with respect to application, further manufacture or other use of the products and parts, RegO® shall not be liable for such technical advice or any such advice provided to buyer by any third party and buyer assumes all risks of such advice and the results thereof.

NOTE: Some states do not allow the exclusion or limitation of incidental, consequential or punitive damages, so the above limitation or exclusion may not apply to you. The warranty gives you specific legal rights, and you may have other rights that vary from state to state. The portions of the limited warranty and limitation of liability shall be considered severable and all portions which are not disallowed by applicable law shall remain in full force and effect.

The benefits given by the Limited Warranty above are in addition to any other rights and remedies to which you may be entitled by law.

NOTE TO AUSTRALIAN PURCHASERS: The following applies if you purchased this product as a "consumer" as defined in the Australian Consumer Law. Our goods come with guarantees that cannot be excluded under the Australian Consumer Law. You are entitled to a replacement or refund for a major failure and compensation for any other reasonably foreseeable loss or damage. You are also entitled to have the goods repaired or replaced if the goods fail to be of acceptable quality and the failure does not amount to a major failure. Information regarding how to return a product and make a claim under this Limited Warranty is set forth below.

Nothing in this document purports to modify or exclude your rights if any under the Australian Consumer Law, or other laws which cannot be lawfully be modified or excluded.

WARNING

All RegO® products are mechanical devices that will eventually become inoperative due to wear, corrosion and aging of components made of materials such as rubber, etc. The environment and conditions of use will determine the safe service life of these products. Periodic inspection and maintenance are essential to avoid serious injury and property damage.

Many RegO® products are manufactured components which are incorporated by others on or in other products or systems used for storage, transport, transfer and otherwise for use of toxic, flammable and dangerous liquids and gases. Such substances must be handled by experienced and trained personnel only, using accepted governmental and industrial safety procedures.

NOTICE TO USERS OF PRODUCTS

The Limited Warranty stated above is a factory warranty to the first purchasers of RegO® products. Since most users have purchased these products from RegO® distributors, to make a claim under this Limited Warranty the user must within thirty (30) days after the user's discovery of what user believes is a defect, notify in writing and return the product (at the user's expense) to the distributor from whom he purchased the product/part. The distributor may or may not at the distributor's option choose to submit the product/parts to RegO®, pursuant to this Limited Warranty. Failure by buyer to give such written notice and return the product within thirty (30) days shall be deemed an absolute and unconditional waiver of buyer's claim for such defects. Acceptance of any alleged defective product/parts by RegO's distributor for replacement or repairs under the terms of RegO's Limited Warranty in no way determines RegO's obligations under this Limited Warranty.

Because of a policy of continuous product improvement, RegO® reserves the right to change designs, materials or specifications without notice.



Elon, N.C. 27244 U.S.A. Phone +1 (336) 449-7707 Fax (336) 449-6594 www.regoproducts.com

RegO® is a registered trademark of Engineered Controls International, LLC.

Printed in the U.S.A. REV E 05-0923-0811
Instruction Sheet EA7814-301